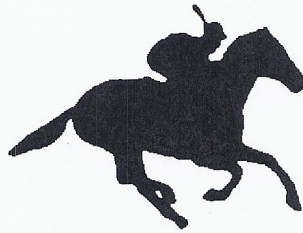


# CENTAUR



## FREE FLOW EXERCISER SERVICE MANUAL & INSTALLATION DIAGRAMS

5761 RIDGEVIEW AVENUE  
MIRA LOMA, CALIFORNIA 91752  
(951) 685-7337 FAX (951) 685-0341  
1-800-962-8050  
[www.hotwalkers.com](http://www.hotwalkers.com)  
[www.equinecisers.com](http://www.equinecisers.com)  
E-Mail: [centaur@hotwalkers.com](mailto:centaur@hotwalkers.com)

## TABLE OF CONTENTS

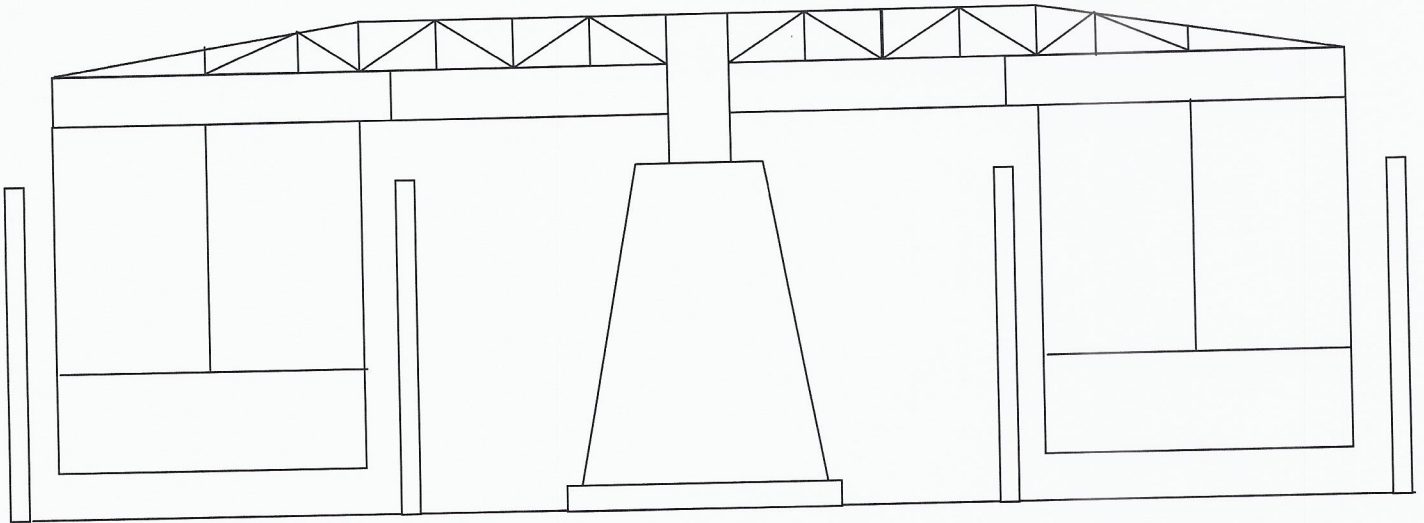
Unloading the Exerciser	Page 12
Site Preparation	Page 3, 4
Grading	Page 3,4
Concrete Pad Installation	Page 5, 6
Electrical Installation	Page 7, 9, 23, 24, 25
Water & Drain Line Installation	Page 8, 10, 11
Sprinkler Installation	Page 11
Fenner Transtorque Collar	Page 13
Head Structure Installation	Page 12, 13
Arm Installation	Page 14
Turn Buckle Diagram	Page 15, 16
Fence Panel Installation	Page 17, 20
Screen Charger Installation	Page 18, 19, 20, 21, 22
Diagram for Electrically Charged Screens	Page 20, 22
General Electrical Hook Up	Page
Computerized Controller Wiring	Page
Control Box Wiring	Page 26, 27
Operating Instructions	Page 28, 30
Do's & Don'ts	Page 29
Control Box Operating Instructions	Page 30
Limited Warranty	Page 31, 32
Maintenance & Lubrication Schedule	Page 33
Pillow Block Maintenance	Page 33
Replacement Parts	Page 33
Nord Drive System	Page 40, 41, 42, 43
Falk Steel Flex Couplings	Page 34, 35, 36, 37, 38, 39

# ATTENTION:

When most Graders and Grading Contractors hear 0% grade, they will grade at 1% to allow for proper drainage. While this is suitable for most buildings, it is **NOT** suitable for the Centaur Equinecisers. To install the fencing, and the screens properly there must be a **true 0% grade**. From 4 feet, outside of the diameter desired, and the diameter desired, the ground must be completely **FLAT**.



# Grading Diagram



Entire Pad **MUST** be flat, **NO** Grade Deviation or Fall (**NO 1% GRADE FOR DRAINAGE**)

Pad will be 4 ft. larger than the diameter of the Equineciser Model.

TOP OF THE SLAB **MUST** BE 5 ½" ABOVE FINISHED EXERCISING SURFACE  
(THE ACTUAL FOOTING/SURFACE HORSES WILL BE EXERCISING ON).

Apply **FINAL** exercising surface, **AFTER** fencing has been **INSTALLED**.

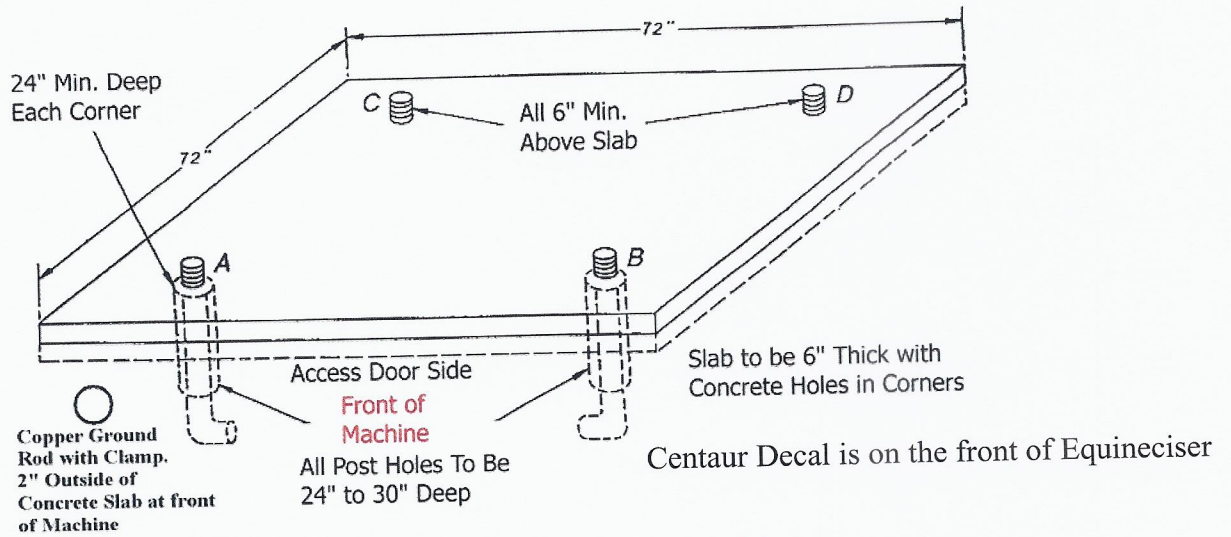
**Please Note:** When most Graders and Grading Contractors hear 0% grade, they will grade at 1% to allow for proper drainage. While this is suitable for most buildings, it is **NOT** suitable for the Centaur Equinecisers. To install the fencing, and the screens properly there must be a **true 0% grade**. From 4 feet, outside of the diameter desired, and the diameter desired, the ground must be completely **FLAT**.

Due to numerous installations where the grading and/or the electrical was not done correctly, our Project Coordinator, has had to layover, and incurred more costs than necessary. Now we charge an additional \$1,000.00 to our clients, should our Project Coordinator arrive at the jobsite, and find the pad and/or electrical incorrect. This price is for food, lodging, truck & tool rentals for 2 additional days **ONLY**, thereafter it is, \$500.00 per day.

The above prices are all based on geographical location of jobsite, the prices could vary upwards. Should you choose one of the optional installation packages offered by Centaur, the above mentioned charges are **NOT** included in the prices, and will be added to the installation prices if necessary.



# CONCRETE DIAGRAM 1



Angular Projection is a visual aid ONLY and is NOT to be scaled.

**Electrical Conduits MUST be installed Prior to concrete pour, see Electrical Diagrams for details.**

## Center Point for Concrete Anchors:

- A to B = 46 1/2"
- C to D = 46 1/2"
- A to C = 57 1/2"
- B to D = 57 1/2"

## Diagonals:

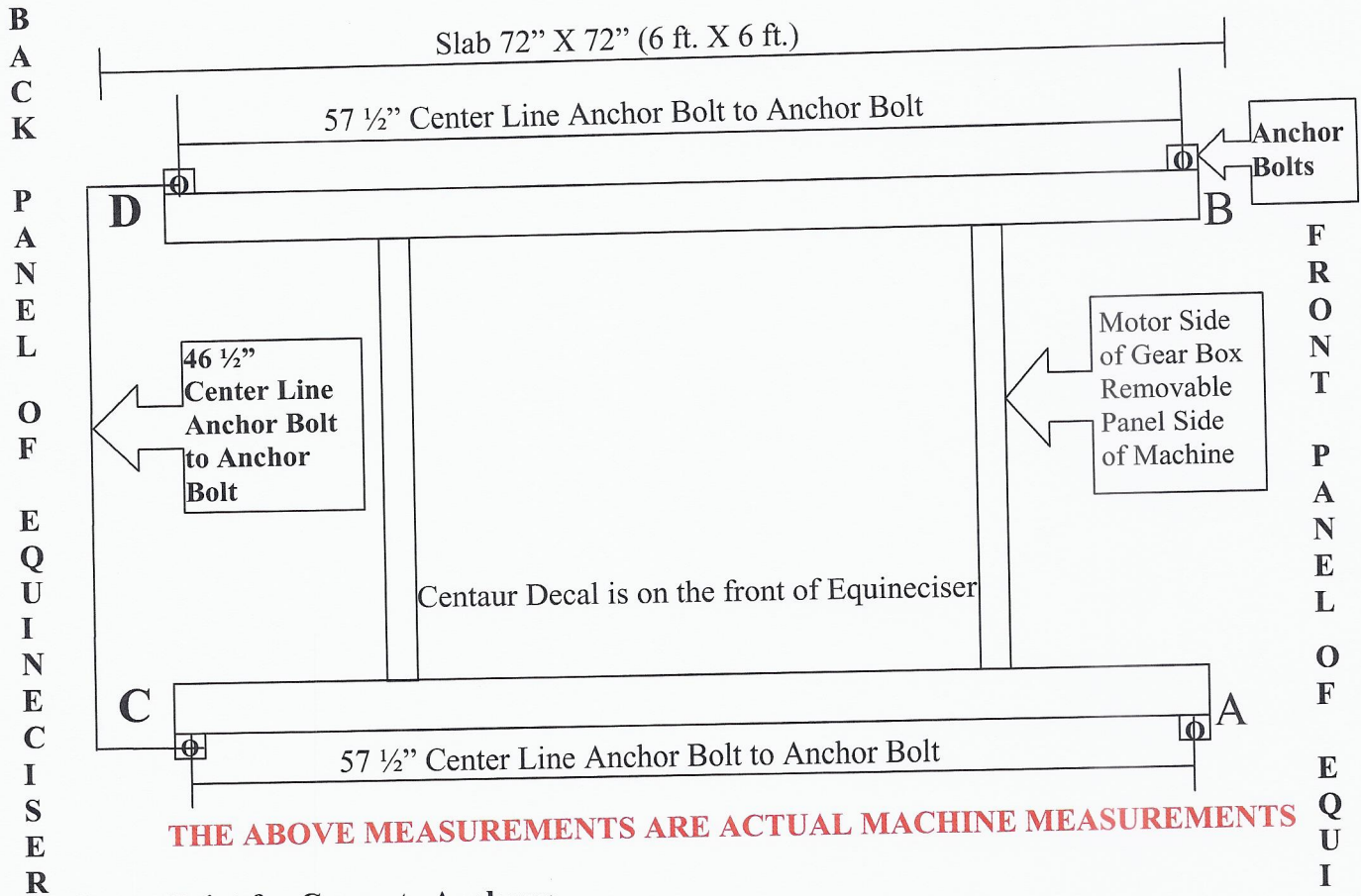
- A to D = 74 1/2"
- B to C = 74 1/2"

Anchor Bolts are 3/4" in diameter, and can either be 18" or 24" in length.

**NOTE: All Dimensions are from the Bolts NOT the Slab.**

Pad should be 72" X 72" (6 ft. X 6 ft.) Square.

# CONCRETE DIAGRAM 2



## Center Point for Concrete Anchors:

- A to B = 46 1/2"
- C to D = 46 1/2"
- A to C = 57 1/2"
- B to D = 57 1/2"

## Diagonals:

- A to D = 74 1/2"
- B to C = 74 1/2"

Anchor Bolts are 3/4" in diameter, and can either be 18" or 24" in length.

**NOTE: All Dimensions are from the Bolts NOT the Slab.**

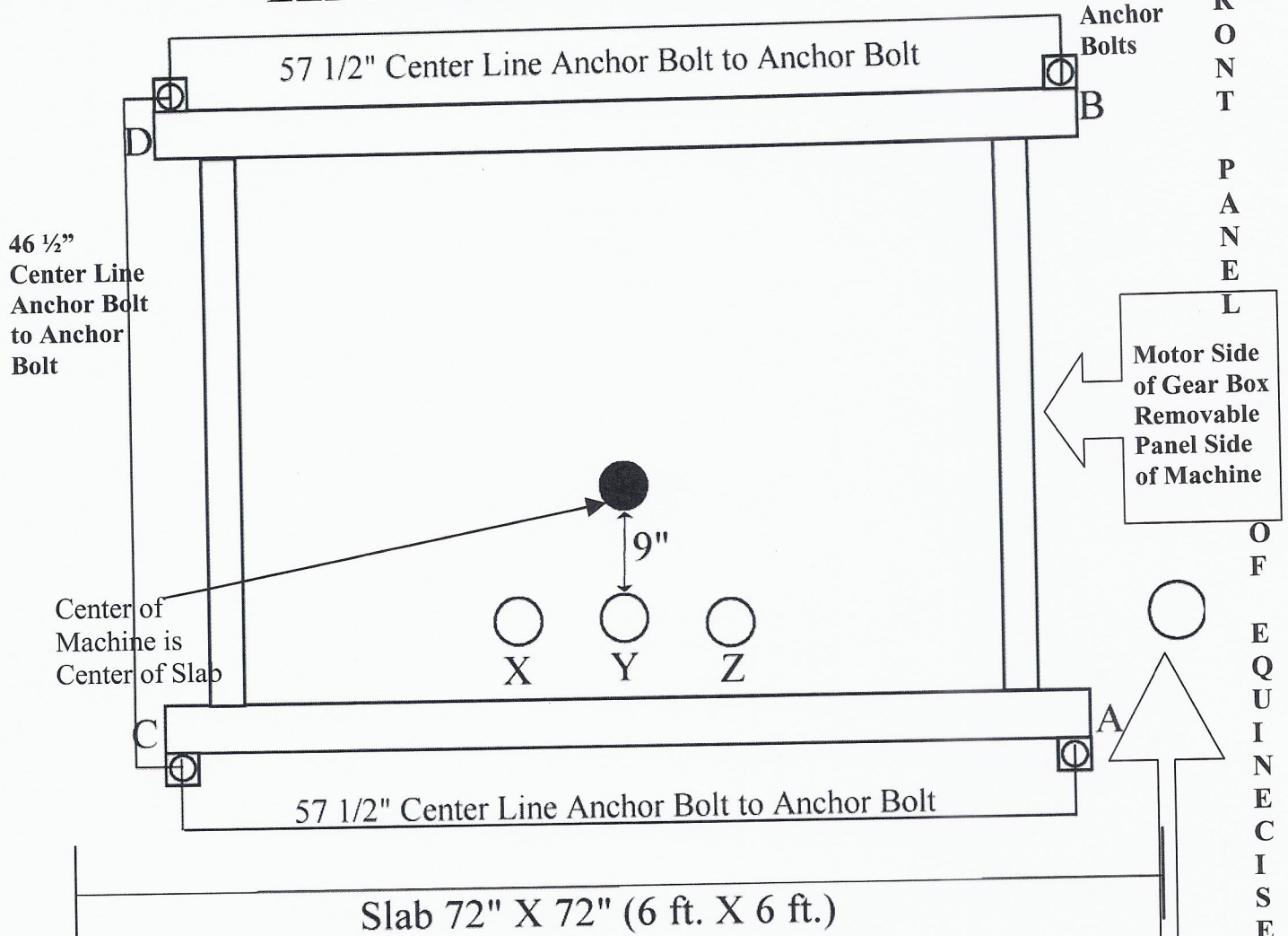
Pad should be 72" X 72" (6 ft. X 6 ft.) Square.

**Machine MUST be 5 1/2" above final grade finish grade of horse walking surface Area.**

# ELECTRICAL DIAGRAM 1

B  
A  
C  
K  
  
P  
A  
N  
E  
L  
  
O  
F  
  
E  
Q  
U  
I  
N  
E  
C  
I  
S  
E  
R

F  
R  
O  
N  
T  
  
P  
A  
N  
E  
L  
  
O  
F  
  
E  
Q  
U  
I  
N  
E  
C  
I  
S  
E  
R



**THE ABOVE MEASUREMENTS ARE ACTUAL MACHINE MEASUREMENTS**

**X = Conduit to Power Supply**

20 AMP 220 Volt Circuit and  
1 - 15 AMP 110 Volt Circuit,  
in **ONE** Conduit. **Both Circuits are to be dedicated**

**Y = Conduit to Control Panel**

3/4" Conduit with **TWO** Black wires  
and **ONE** Green wire.

**Z = Conduit to Control Panel**

3/4" Conduit for wire loom.  
(Wire loom supplied by Centaur)  
**IF RUN IS LONGER THAN 50 FT. CONTACT CENTAUR CORP.**

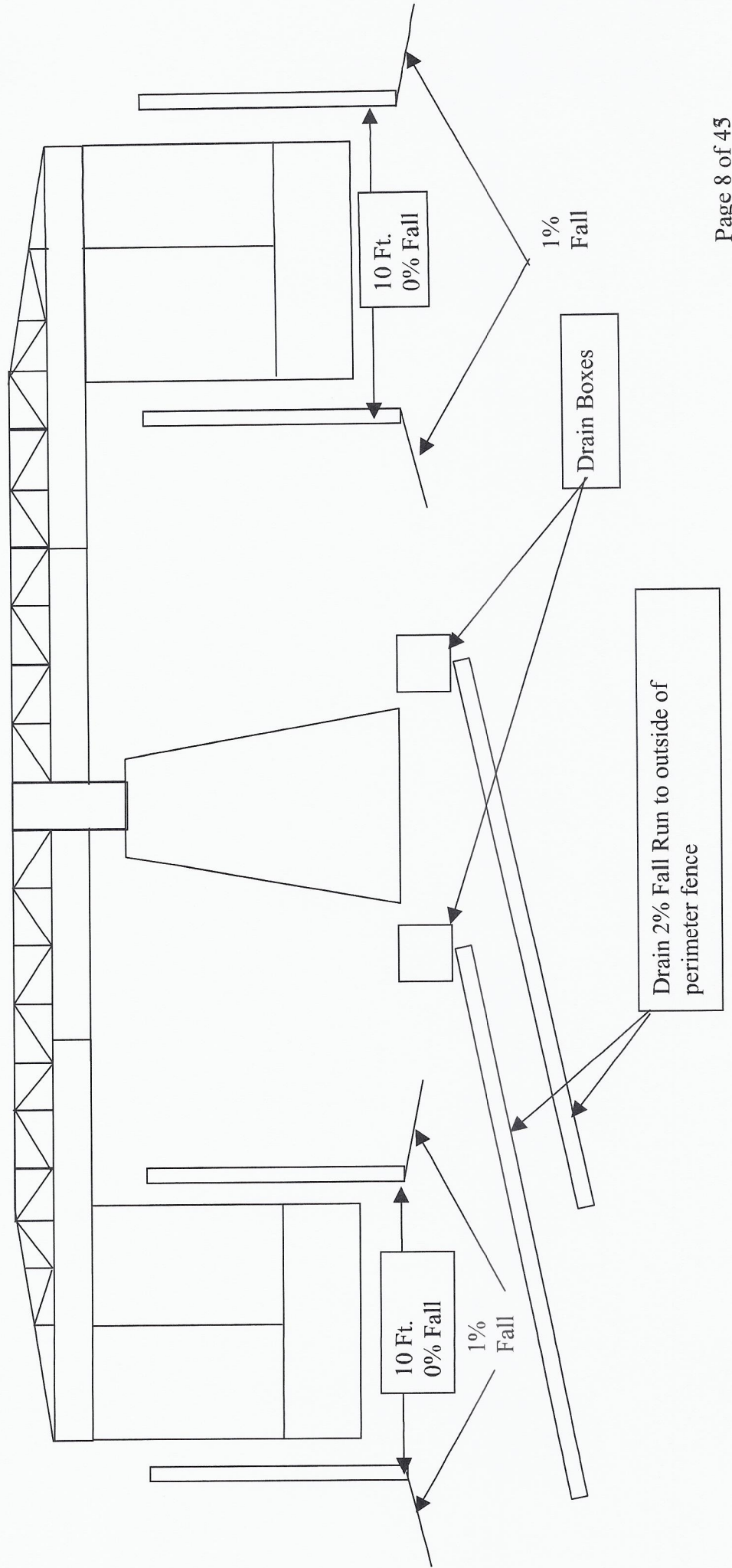
**USE #10 WIRE IF RUN IS UNDER 100 FT. For 220 Volt Power to Equineciser.**  
**Use #12 Wire 110 Volt to Shocker.**  
**IF RUN IS LONGER THAN 100 FT. CONTACT CENTAUR CORP.**

X & Y To be connected into a 2  
gang weather proof box

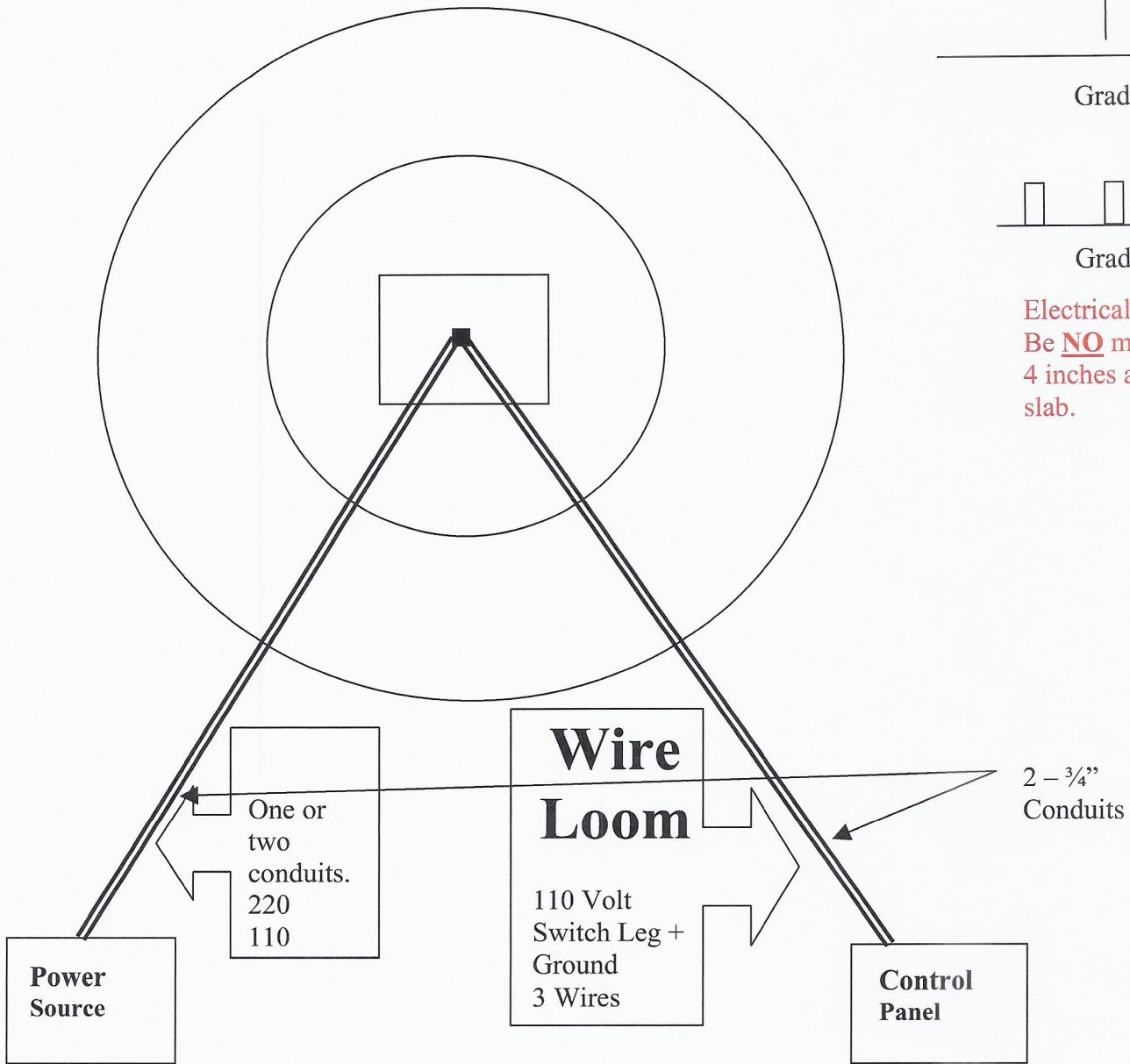
**Copper Ground  
Rod with Clamp  
MUST BE  
INSTALLED.**  
(2" Outside of  
concrete slab at  
front of machine.)



# Optional Drain Line for Centaur Free Flow Equineciser



# Electrical Conduit Overview



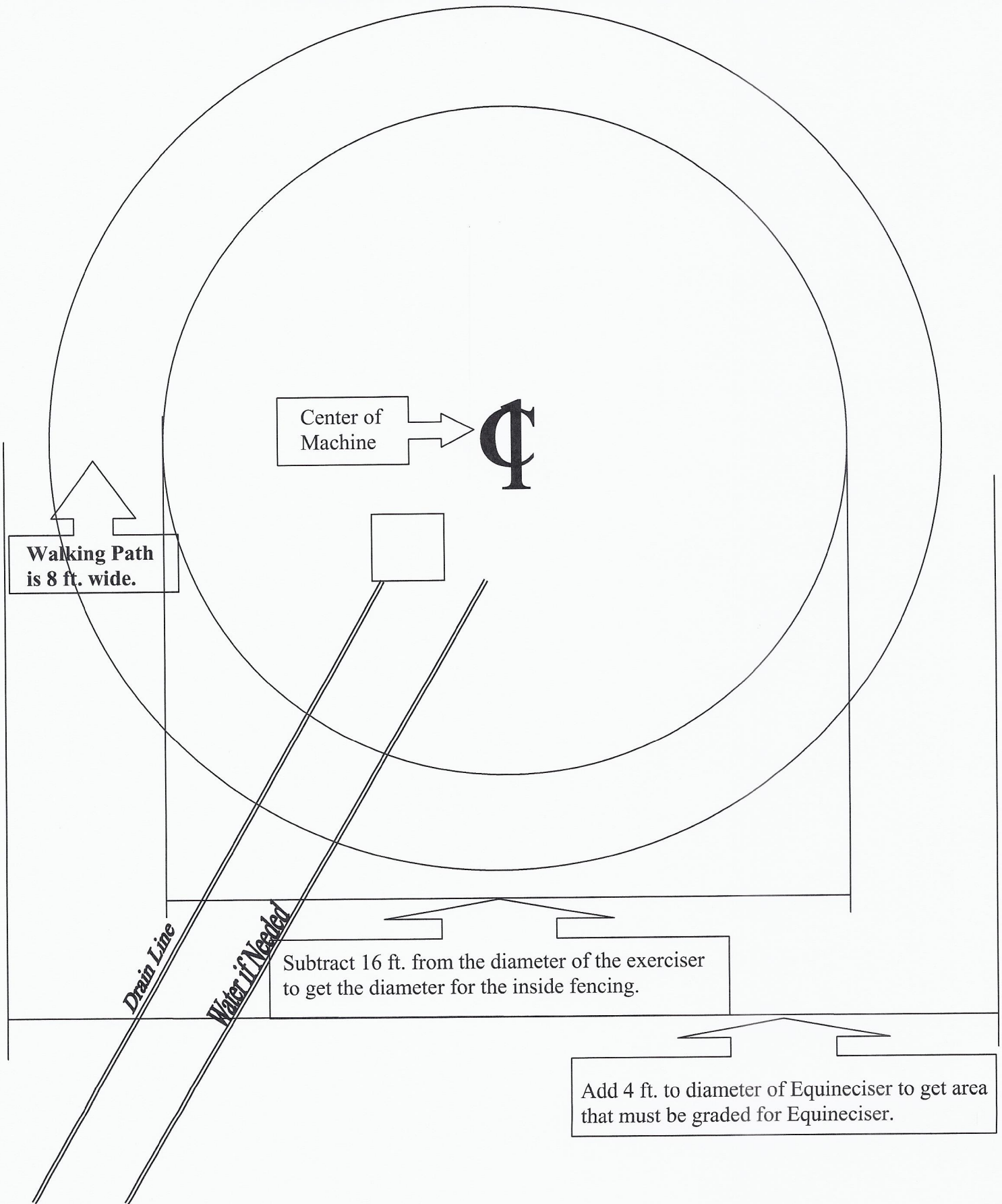
Electrical Stubs to Be **NO** more than 4 inches above slab.

**NEED**

110 Circuit to Duplex plug at Equineciser, Switched to Control Panel.

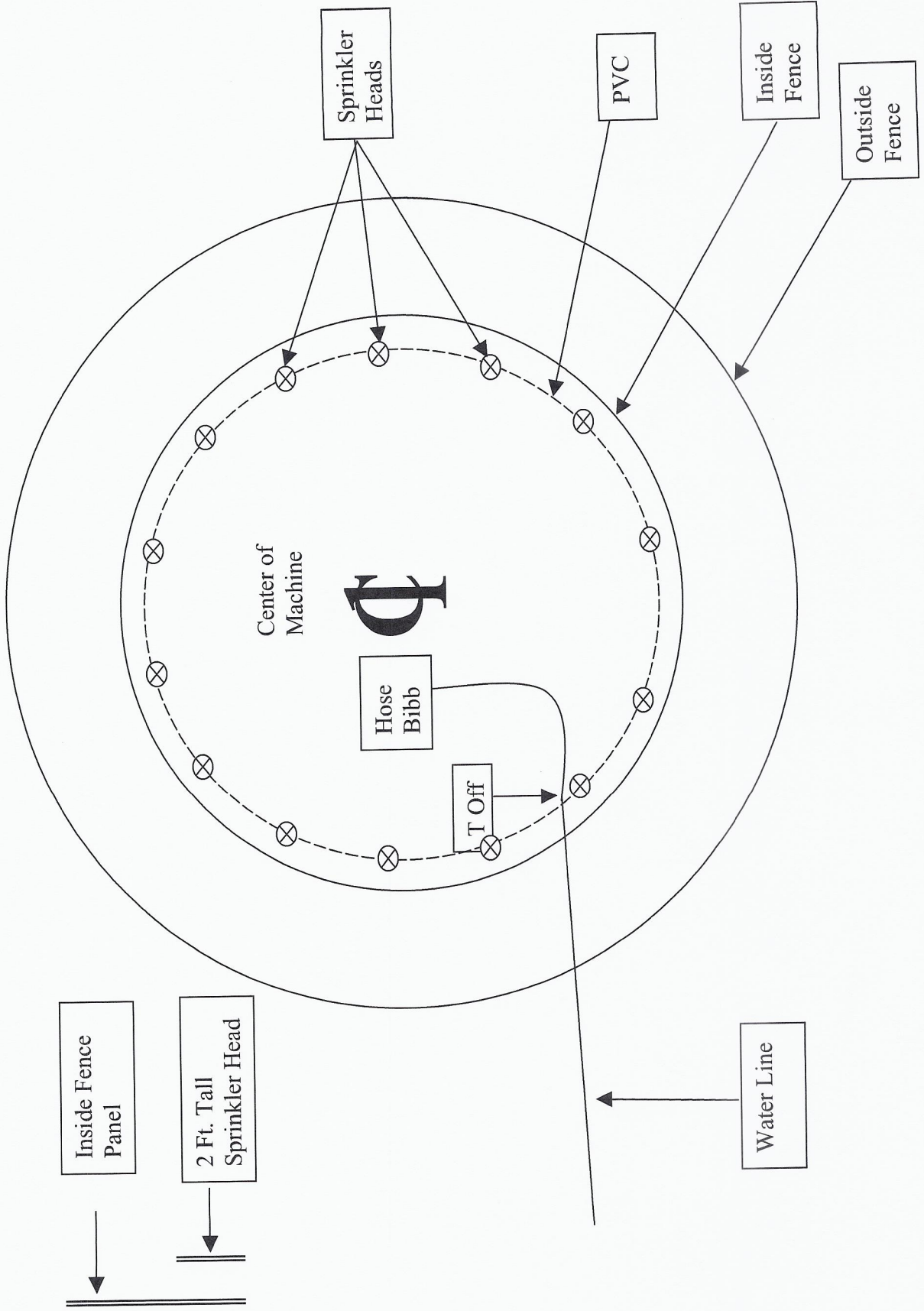
220 to Disconnect at Equineciser.

# Water & Drain Line Overview





# Optional Sprinkler System for Exerciser's Path, for Centaur Free Flow Equineciser



## Unloading the Equineciser:

We strongly suggest that you place all of the fence panels, in 2 stacks near but off of the graded pad.

To unload the equineciser from the truck, you will need to have a 6 ft. ladder, #2 phillips screwdriver (or screw gun), heavy chains. You will need to place the ladder on the bed of the semi, so that you can reach the top of the equineciser. You will need to remove the screws holding the lid on the equineciser, set the screws & lid off to the side, until the equineciser has been placed on the pad.

You will the need to wrap the chain around the upper cross members of the equineciser base. Once the chain has been secured, you will then need to attach the chain to the forks of the forklift, (or bucket of the front end loader). Once the chains are secured, remove ladder from bed of truck, and all personnel from bed of semi. Lift the equineciser up, remove from truck, and place on concrete slab. (Note: The front of the equineciser is the panel with the Centaur Label on it).

Once the equineciser base has been removed from the truck, & placed on the concrete pad. Remove the arms, head, screens, mats, control stand, fence panels & cardboard boxes from semi. Please check items for damage.

Screw the lid back on to the top of the equineciser, prior to head assembly.

Open cardboard boxes, and find the small white box with the transtorque nut. Inside this box you will find a piece of emery cloth.

Remove shrink wrap & any tape from shaft. Sand the shaft and the inside of the hole on the bottom of the head, with the emery cloth, take the transtorque nut, rotate the black nut completely clockwise to reduce the brass slit insert to a smaller diameter, tap transtorque nut inside the hole on the bottom of the head, with a rubber mallet (you can also place a wooden board over the nut, and tap the wood with a regular hammer). **DO NOT HIT THE NUT DIRECTLY WITH A METAL HAMMER.** Turn the black nut counter clockwise so that it does not fall out of the head. Slowly lower head onto the shaft, keeping the head level (this requires 2 men, on either side of the machine guiding the head while the forklift or tractor operator lowers the head). You will need to keep backing off the black nut counterclockwise so that the head will gradually slide down on the shaft. The head will stop 4 to 5 inches from the lid, hand rotate the head in a clockwise direction one complete rotation, this will drop the head down about ¼” further onto the locking notch, which is located on the vertical shaft. Use a plumbers wrench (and cheater bar if needed) to tighten the nut until it is snug, do not overtighten.



## Unloading the Equineciser:

We strongly suggest that you place all of the fence panels, in 2 stacks near but off of the graded pad.

To unload the equineciser from the truck, you will need to have a 6 ft. ladder, #2 phillips screwdriver (or screw gun), heavy chains. You will need to place the ladder on the bed of the semi, so that you can reach the top of the equineciser. You will need to remove the screws holding the lid on the equineciser, set the screws & lid off to the side, until the equineciser has been placed on the pad.

You will the need to wrap the chain around the upper cross members of the equineciser base. Once the chain has been secured, you will then need to attach the chain to the forks of the forklift, (or bucket of the front end loader). Once the chains are secured, remove ladder from bed of truck, and all personnel from bed of semi. Lift the equineciser up, remove from truck, and place on concrete slab. (Note: The front of the equineciser is the panel with the Centaur Label on it).

Once the equineciser base has been removed from the truck, & placed on the concrete pad. Remove the arms, head, screens, mats, control stand, fence panels & cardboard boxes from semi. Please check items for damage.

Screw the lid back on to the top of the equineciser, prior to head assembly.

Open cardboard boxes, and find the small white box with the transtorque nut. Inside this box you will find a piece of emery cloth.

Remove shrink wrap & any tape from shaft. Sand the shaft and the inside of the hole on the bottom of the head, with the emery cloth, take the transtorque nut, rotate the black nut completely clockwise to reduce the brass slit insert to a smaller diameter, tap transtorque nut inside the hole on the bottom of the head, with a rubber mallet (you can also place a wooden board over the nut, and tap the wood with a regular hammer). **DO NOT HIT THE NUT DIRECTLY WITH A METAL HAMMER.** Turn the black nut counter clockwise so that it does not fall out of the head. Slowly lower head onto the shaft, keeping the head level (this requires 2 men, on either side of the machine guiding the head while the forklift or tractor operator lowers the head). You will need to keep backing off the black nut counterclockwise so that the head will gradually slide down on the shaft. The head will stop 4 to 5 inches from the lid, hand rotate the head in a clockwise direction one complete rotation, this will drop the head down about ¼" further onto the locking notch, which is located on the vertical shaft. Use a plumbers wrench (and cheater bar if needed) to tighten the nut until it is snug, do not overtighten.



# INSTALLATION INSTRUCTIONS

A Trantorque GT Keyless Bushing offers flexible and easy installation while providing exceptional holding power. To ensure a Trantorque GT unit performs as specified, it must be installed properly.

**Warning: Use no lubricants in this installation.**

1. Shaft and component bore must be within  $\pm 0.003"$  ( $\pm 0.08\text{mm}$ ) [ $\pm 0.0015"$  ( $\pm 0.04\text{mm}$ ) Mini Series] of stated bore diameter and must have a surface finish of 32-125 Ra (roughness average). If the surface finish is outside these specified values, consult Fenner Drives.
2. Both shaft and component bore must be completely free of paint, grease, oil, and dirt. If necessary, clean the surfaces with a non-petroleum based solvent, such as isopropyl alcohol.

**Warning: Do not lubricate the Trantorque GT bushing or shaft. The use of any lubricant on the contact surfaces could result in bushing failure and will void all warranties.**

3. Insert the Trantorque GT unit into the component to be mounted, **making sure the mating hub is flush against the shoulder at the hex flats.**
4. Position the assembly at the desired location on the shaft and hand-tighten the nut (clockwise) until the assembly becomes snug on the shaft.

**Warning: Do not hammer or use any type of impact to force the Trantorque GT assembly along the shaft.**

**Warning: The shaft must fully engage the shaft gripping area (Figure 1) of the Trantorque GT unit. Figure 2 illustrates minimum shaft engagement.**

5. Using a torque wrench, tighten the nut to the proper installation torque. See table for torque value. (Note: Fenner Drives has available crowfoot wrenches for square drives in sizes from 1/2" to 3-1/2".) The hex flats on the outer element are provided for counter-torque, eliminating the need to hold the component or shaft while applying installation torque.

Note: At full installation torque, the assembly will have moved approximately 0.075" ( $\pm 1.9\text{mm}$ ) [ $0.045"$  ( $\pm 1.1\text{mm}$ ) Mini Series] axially along the shaft away from the nut. If axial position is critical it may be necessary to loosen the nut and reposition the assembly.

**Warning: Over-tightening the nut could damage the Trantorque GT unit and/or the mounted component.**

**Do not use an impact wrench in the installation.**

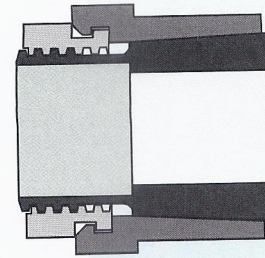


Figure 1

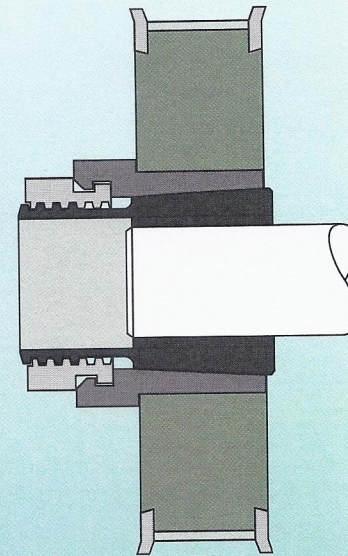
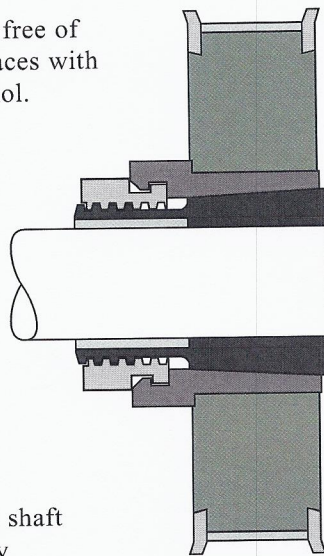


Figure 2

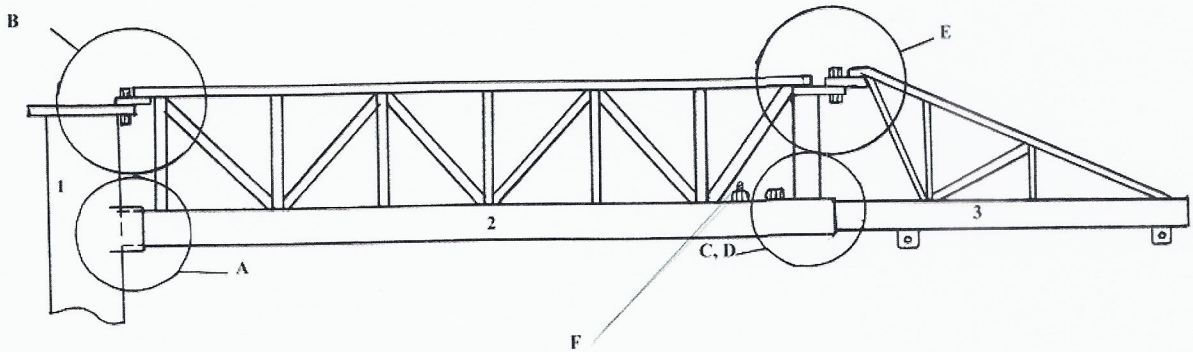
## Installation Torque on Nut

	Inch Pound System		Metric System	
	Shaft Size	In. Lbs.	Shaft size	N-m
MINI SERIES	3/16-1/4	125	5-6mm	14.1
	5/16-3/8	150	7-9mm	17.0
	7/16-1/2	175	10-12mm	19.8
	9/16-5/8	200	14-16mm	22.6
	3/4	700	17mm	80.0
STANDARD SERIES	5/8-3/4	1200	15-19mm	136
	13/16-1	1500	20-25mm	170
	1-1/16-1-1/4	2000	28-32mm	225
	1-5/16-1-1/2	2300	34-38mm	260
	1-9/16-1-3/4	2800	40-42mm	316
	1-13/16-2	4900	45-50mm	554
LARGE SERIES	2-1/16-2-1/4	5300	55mm	600
	2-5/16-2-1/2	5600	60mm	635
	2-9/16-2-3/4	6000	65-70mm	680
	2-13/16-3	6600	75mm	750



# Arm Assembly

Figure B2.

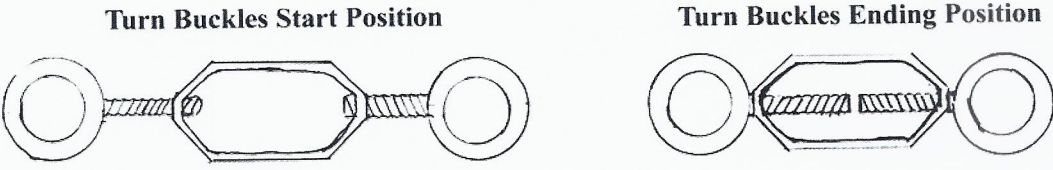
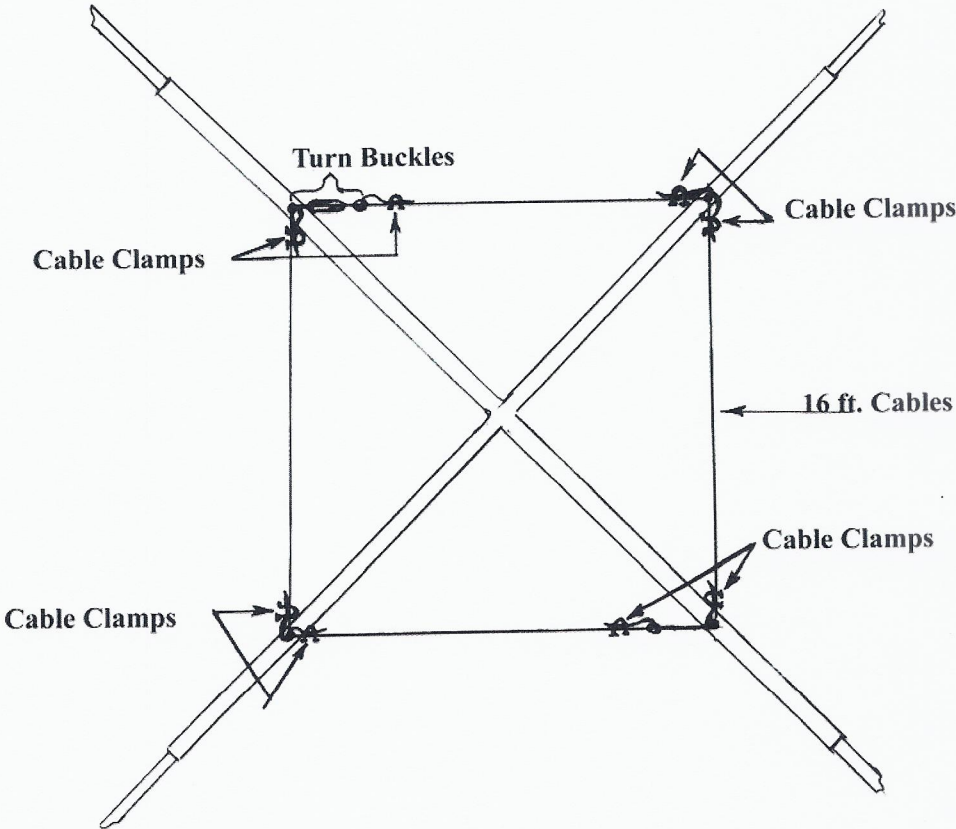


1. Top of Free Flow Exerciser
2. Primary Arm Truss
3. Secondary Arm Truss

- A. Slide Primary Arm Truss into receiving box on head.
- B. Fasten Tabs with Nut & Bolt Assembly.
- C, D. Slide Secondary Arm Truss in receiving end of Primary Arm Truss. Fasten Primary Arm to Secondary Arm with lock Bolt & Nut Assembly.
- E. Fasten Tabs with Nut & Bolt Assembly.
- F. Nut & Bolt that Cable fastens to.

**IMPORTANT:** (See Figures C or C2) You will notice on the super structure there is another bolt that is threaded it lies right behind the first bolt where you inserted the smaller arm. The secondary bolt is where you take your cable pieces, make a small loop on the end of it with a cable clamp and a small loop on the other end with a cable clamp, and you apply them around these additional nuts & bolts you will do 4 of them that way, looking at the diagram that I have included for you on placement of the turnbuckles. There are 2 turn buckles on the inside of the cable that will go opposite each other on 2 of the 6, shorter cables, (length based on model). By rotating the turnbuckles you will apply tension on all the other cables. **IMPORTANT:** make sure the cable clamp nuts are on tight so cable will not slip out.

# Turn Buckle Diagram

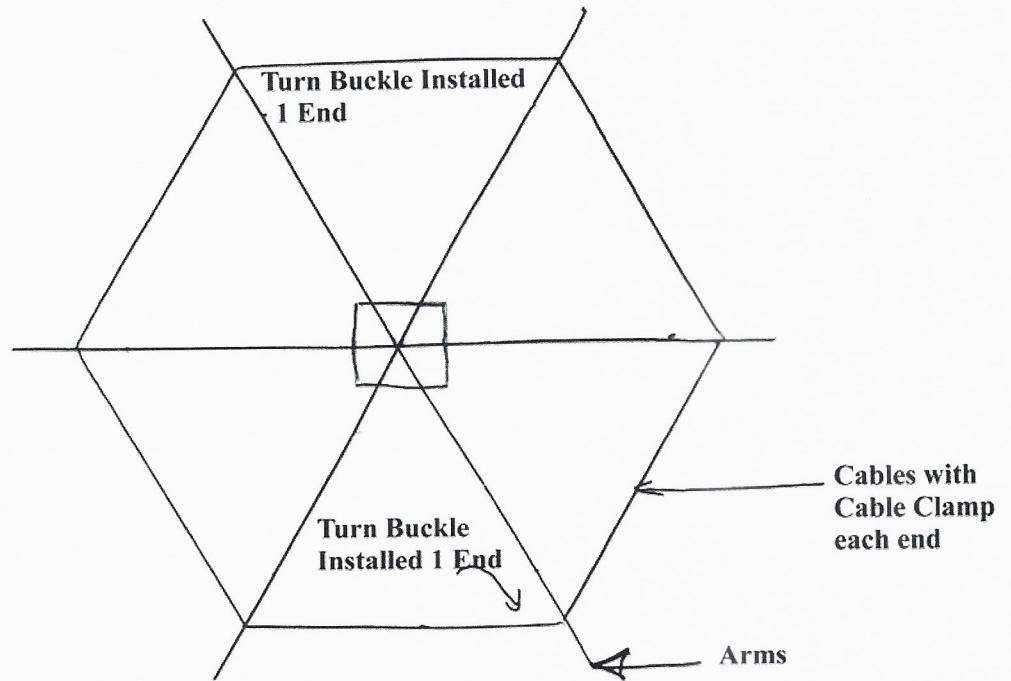


Cable Clamps & Turn Buckle Installation Figure C.



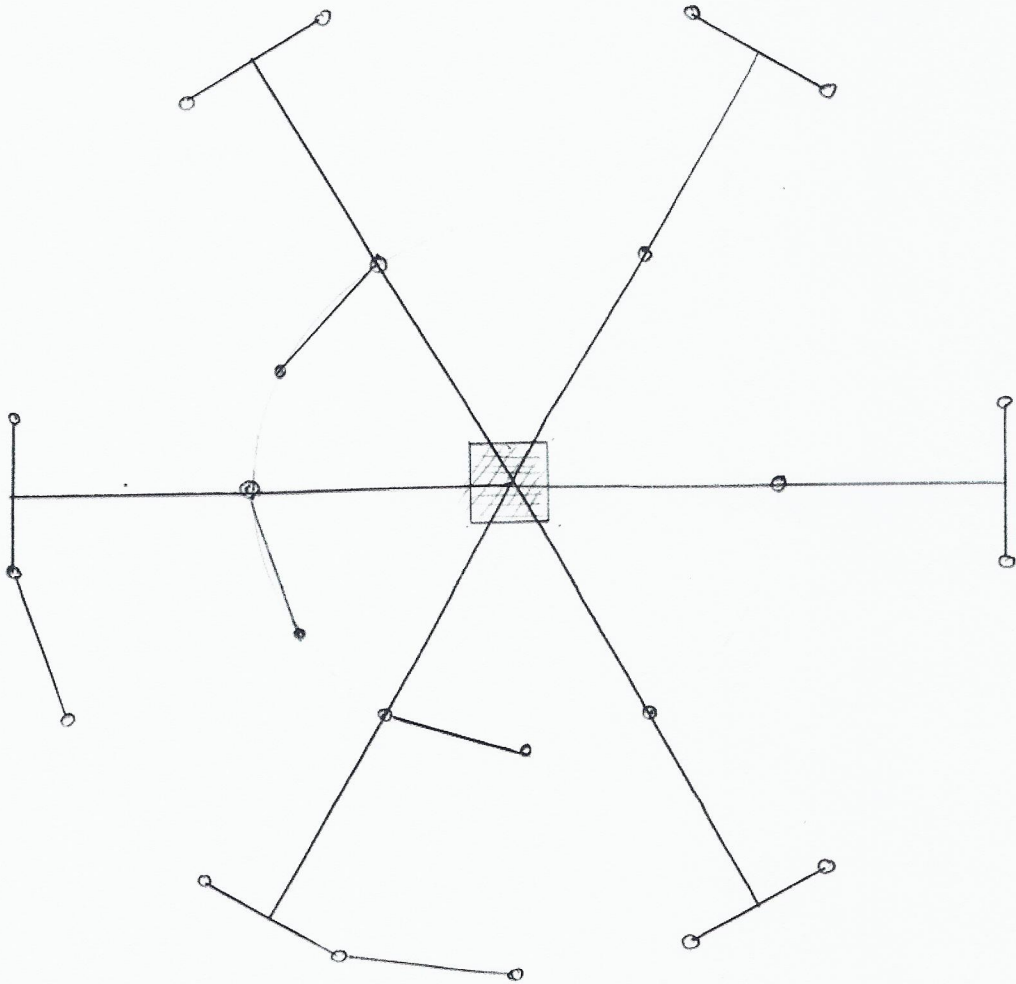
# TURN BUCKLE DIAGRAM

Figure C2.



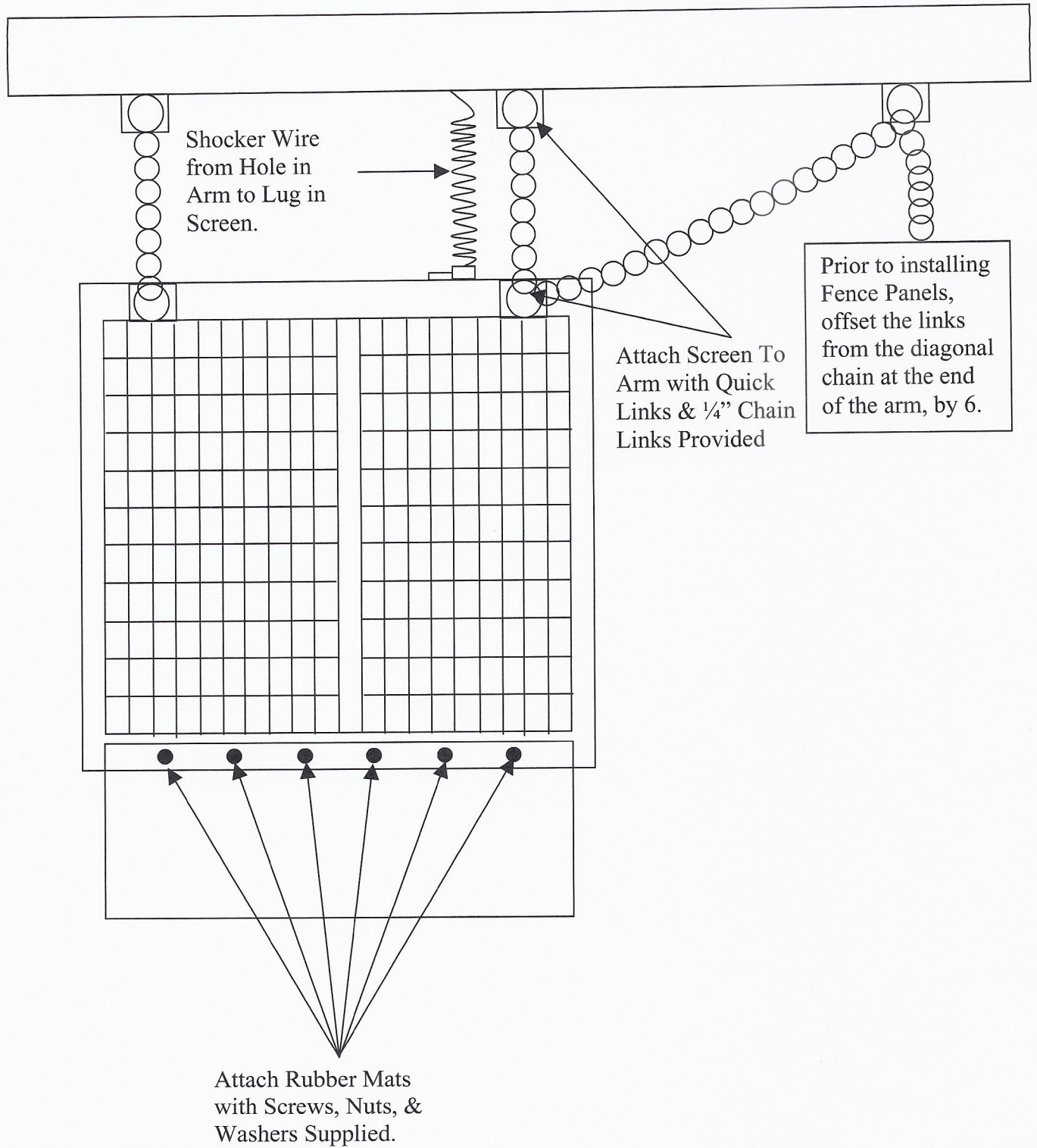
# FENCE PANEL DIAGRAM

Figure E2.



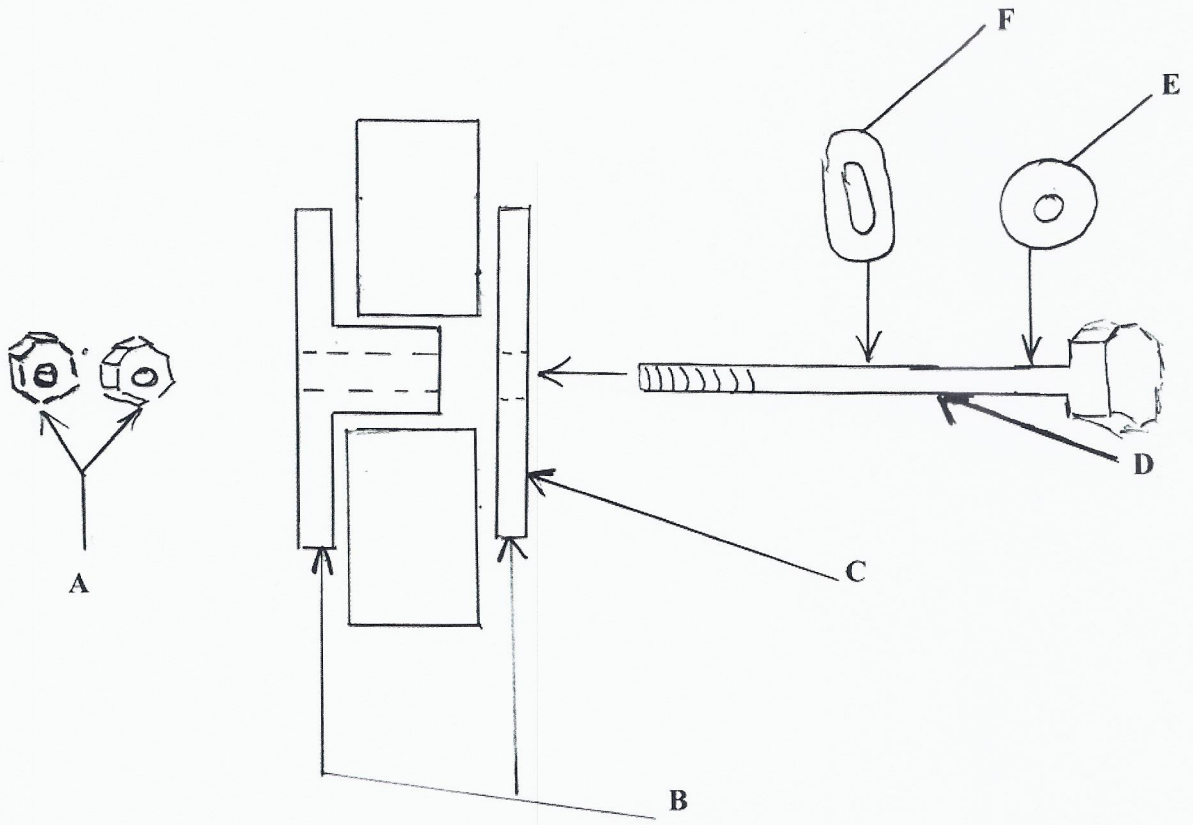
**NOTE: Outside Panels 90 degrees to arm end. Inside Panels are offset/post is under arm.**

## Screen Installation Figure D.

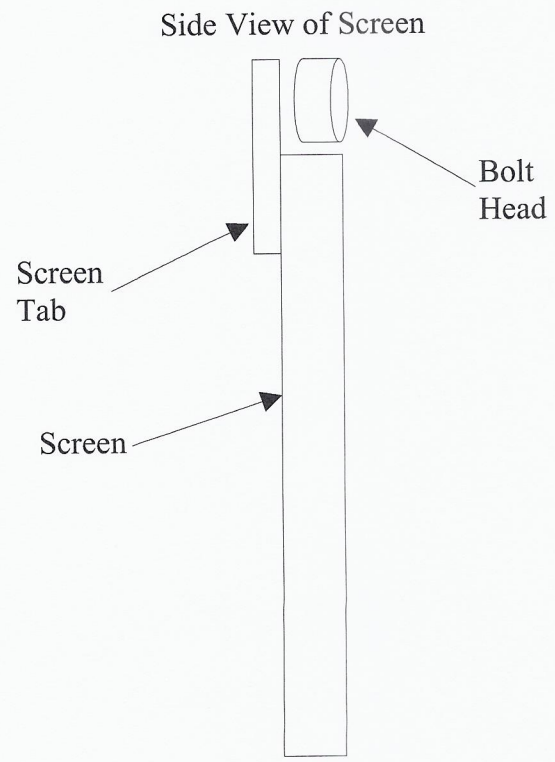




**DIAGRAM FOR ELECTRICALLY CHARGED SCREENS ONLY**



- A. 2 - 3/16" Nuts
- B. Plastic Insert & Plastic Washer
- C. Top view of 1" hole in top of screen hanger
- D. 2 1/2" X 3/16" Bolt
- E. 3/16" Washer
- F. 1<sup>st</sup> Link of chain in 1ft piece.



## **FENCE INSTALLATION (If you purchase it from us)**

Erect the inside fencing first, then erect the outside fencing. (See Figures E & E2). The fence panels are 6ft in length put a mark at 3 ft in (half way on the length) place the first panel so that you have 3 ft to the left and 3 ft to the right of the arm, keeping the welded wire on the inside by the horse. You want to divide the 6ft panel exactly in half perpendicular to the arm. Hold the edge of the screen so that it is 4 to 5 inches away from fence panel. **NOTE:** Machine will not work properly if distance is less than 4 to 5 inches, and horses could get hurt if the distance is more than 4 to 5 inches. Place a second panel to the left or right of the first panel, check the distance from the screen, using the panel clamps, put on at the top of the panel, & one at the bottom. Continue to place panels, one at a time, checking the distance from the screen as each panel is placed. All panels must be level, both horizontally & vertically, they can not lean in or out. Place the inside service gate across from the main entry/exit gate, for easy service access. When installing the outside fencing the distance from the screen should be 4 to 5 inches from the center of each panel.

**Optional Soil Retention System:** We recommend that you install the optional soil retention system, prior to standing the panels. It is much easier to attach each mat to the fence panel while the panel is lying flat. Using a drill with a 3/8 inch bit, drill 2 holes in the top corners of each mat, one in the center of each side, and 2 in the bottom corners. Using the electrical ties, attach the mat to the panel, preferably around the pipe, if possible. Cut off the excess from the wire tie, once it has been secured.

**For the 6 horse, 68 Ft. Diameter Equinecisers** - Put a gate panel at end of each arm 5 sets will be 1 gate, 3 panels, 1 gate, 3 panels, the last set will be 1 gate panel & 2 fence panels.

## **SCREEN INSTALLATION:**

(See Figure D) You will find 2 hangers per each screen, the hangers are pieces of flat steel 2 ½" wide 3/8" thick with 1" hole on center.

On each arm you will find 2 plates welded to the end and 7'6" from the end with a 1" hole in each. Take 1 Quick Link and place in each opening. Now add 1 – 1' piece of ¼" chain to each link.

Now each screen has a tab on each side with a 1" hole. Place 1 Quick Link in each hole. Now attach the screen to each piece of chain. Adjust if necessary to make screen hang level. Take 1 – 2 ft. pieces of chain and attach it to the tab on the bottom of the 3" X 3" big arms with quick link on each end. Used to pull screen off center, so that screen does not hit outside fence.

**NOTE:** The Rubber Mats should be drilled & cut to your desired length. The drill size is 3/8" and there are 6 holes to hand the mat to at the bottom of each screen. They take 6 bolts, 12 washers, & 6 nylock nuts.



## **Installation Instructions for Screen Chargers on all Models of Centaur Free Flow Equinecisers**

To install the electrical charger system you will find a strand of black wire taped to the vertical shaft inside the Equineciser itself.

There is a large keyway (slot) below the top pillow block bearing, on the vertical steel shaft.

Take the black wire & uncoil it & feed it through the shafts keyway (slot) so the wire comes out above the pillow block bearing & under the large flat steel pan.

You will find a hole  $\frac{1}{4}$  in. diameter in the steel pan. Insert the black wire through the hole (from the bottom of the pan) and pull all of the wire through it. So it is under the arm inserts on the round metal shaft, and is resting on the flat steel pan.

At the far end of each small arm by the screen end you will find a hole in the  $2\frac{1}{2}$ " X  $2\frac{1}{2}$ " steel arm, using an electricians snake, slide it through the hole all the way back through the 3" X 3" main support arm.

You will find a hole also in the 3" X 3" using a wire hook grab the electrical snake & pull it through the hole in the 3" X 3" arm.

There were individual black wires sent to you, 1 for each arm.

Attach the 1 piece of black wire to the snake & pull it through the arm. Pull slowly so not to rip insulation from special wire.

Leave about 3 ft. + by head assembly & allow the rest of the wire to pass out of the  $2\frac{1}{2}$ " X  $2\frac{1}{2}$ " arm hole. The arm hole will be on the bottom of the arm

There were also some pieces of clear plastic tubing 1' each sent to you, (it takes 2 – 1 ft. pieces of clear plastic tubing for each arm, one for the 3" X 3" hole & one for the  $2\frac{1}{2}$ " X  $2\frac{1}{2}$ " hole.

Take each of the 1 ft. clear plastic tubes & slide it over the black wire where it enters the 3" X 3" &  $2\frac{1}{2}$ " X  $2\frac{1}{2}$ " arms. The plastic keeps the black wire from rubbing against the steel arm and shorting out.

On top of each screen frame that hangs from the arm with chain, place 1 – lug receiver 6" in from inside of frame – Use a self-drilling tek screw to anchor the lug.

Strip back the black wire & prior to attachment wrap the black wire around a large screwdriver shaft, to make a tight coil – similar to your phone cord. This will allow you to raise or lower the screen chains without tearing the wire loose from the lug connections.

Now go back & take each of the arm wires by the tower head assembly & tie them all together with the one wire that came up through the key slot on the vertical shaft.

Use 1 large wire nut to tie them all together then wrap with electricians splicing tape tightly. Then wrap again with regular electrical tape the wires simply lay on top of the large round steel pan near the central vertical shaft.



See other drawings on how to connect shocker wires from controller to the charge box, (the charge box is mounted on inside wall of the Equineciser). Also refer to the standard concrete & electrical installation information that was also sent to you.

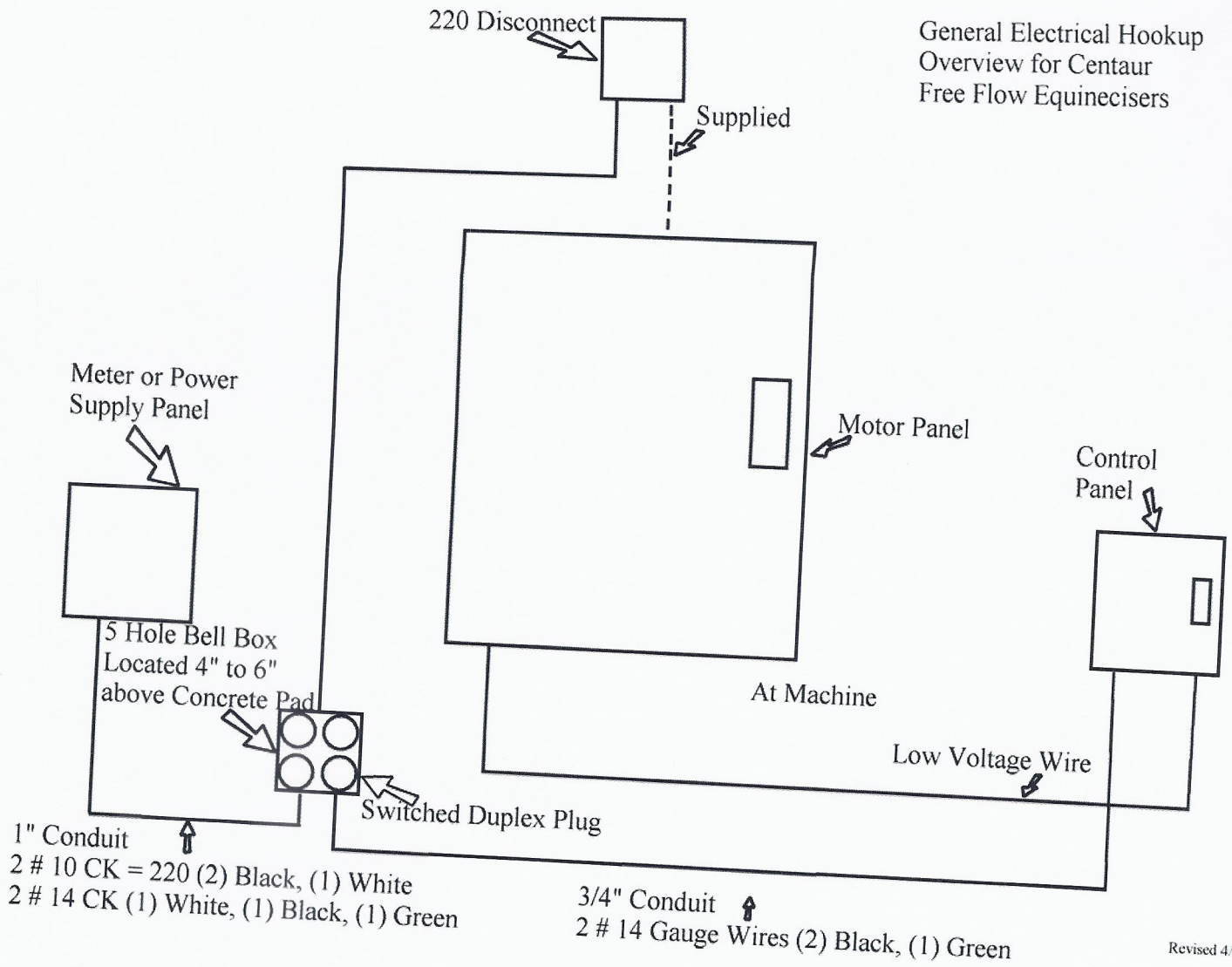
To test if screens are charged: Take a piece of wire and wrap around the ground wire and with the other end of the wire stripped back, touch the screen frame or welded wire on screen you should see a pulsating spark or snap if all connections are grounded & connected properly.

**NOTE:** Moving Screen **CANNOT** touch the Centaur Standard Steel Fence Panels when in place or moving. Chain links **CANNOT** touch the screen or the fence panels.

If the screens rub or touch they will short out the charger box.

# General Electrical Hookup - Overview

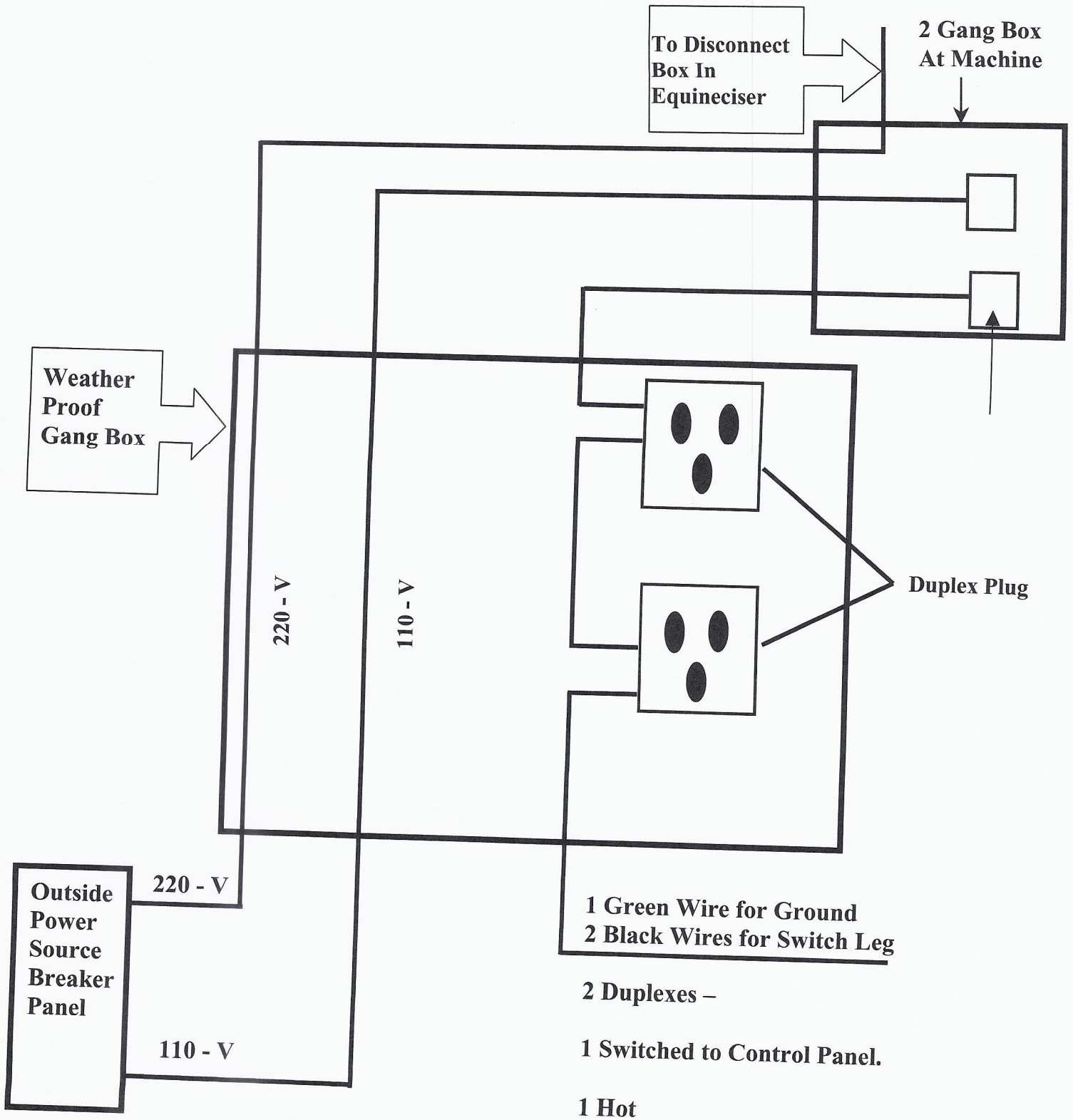
General Electrical Hookup  
Overview for Centaur  
Free Flow Equinecisers



Revised 4/02

**Copper Ground Rod with Clamp MUST BE INSTALLED.**  
(2" Outside of concrete slab at front of machine.)

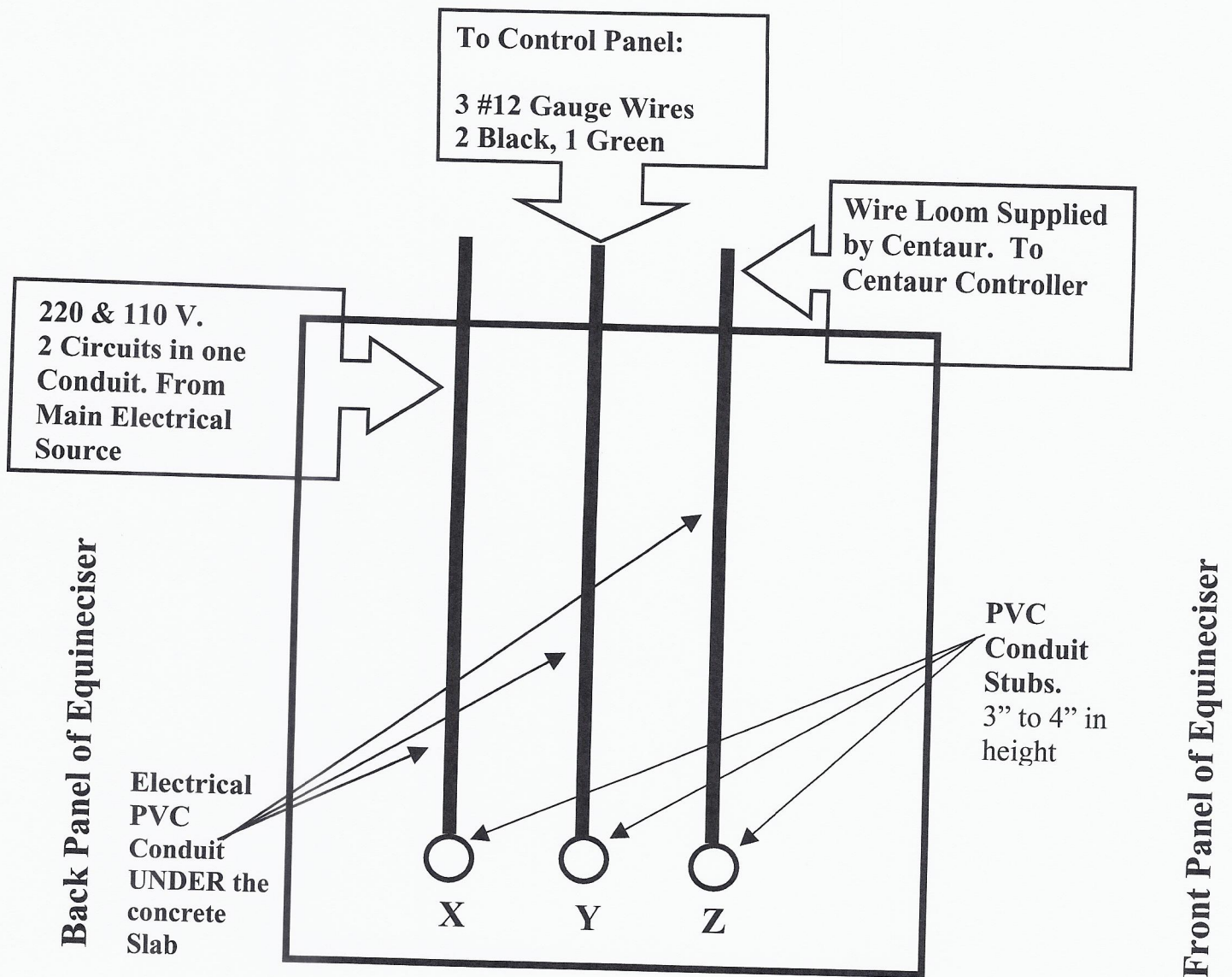
# Centaur Free Flow Equineciser Electrical Diagram 2



**Call our office 1-800-962-8050 with any questions you might have!**



# Centaur Free Flow Equineciser Electrical Diagram 3



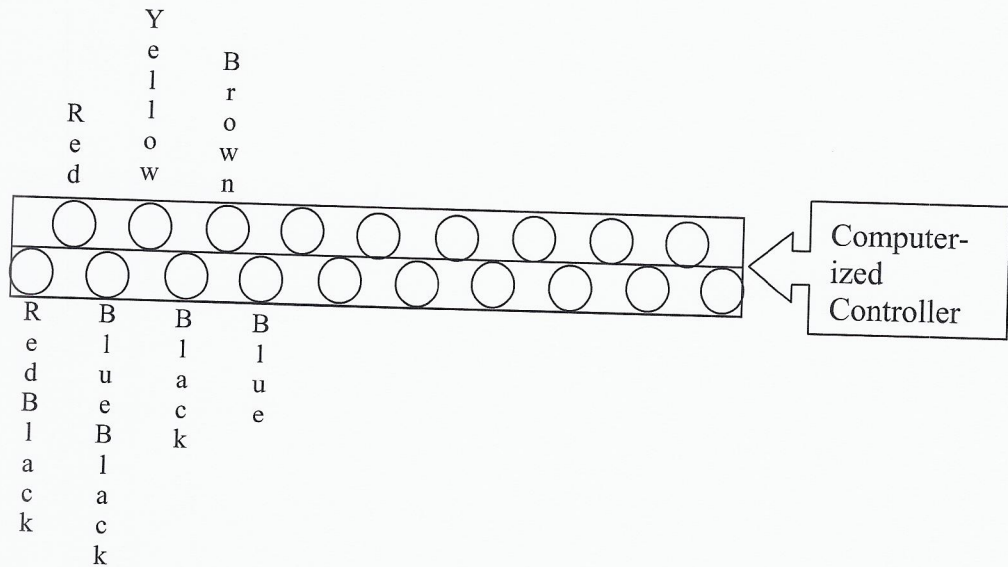
## 6' X 6' Concrete Slab

Call our office 1-800-962-8050 with any questions you might have!

X & Y To be connected into a 2 gang weather proof box

**Copper Ground Rod with Clamp MUST BE INSTALLED.**  
(2" Outside of concrete slab at front of machine.)

## Inside Wiring from Computerized Controller to wire Loom.



### 8 Point Connector Strip

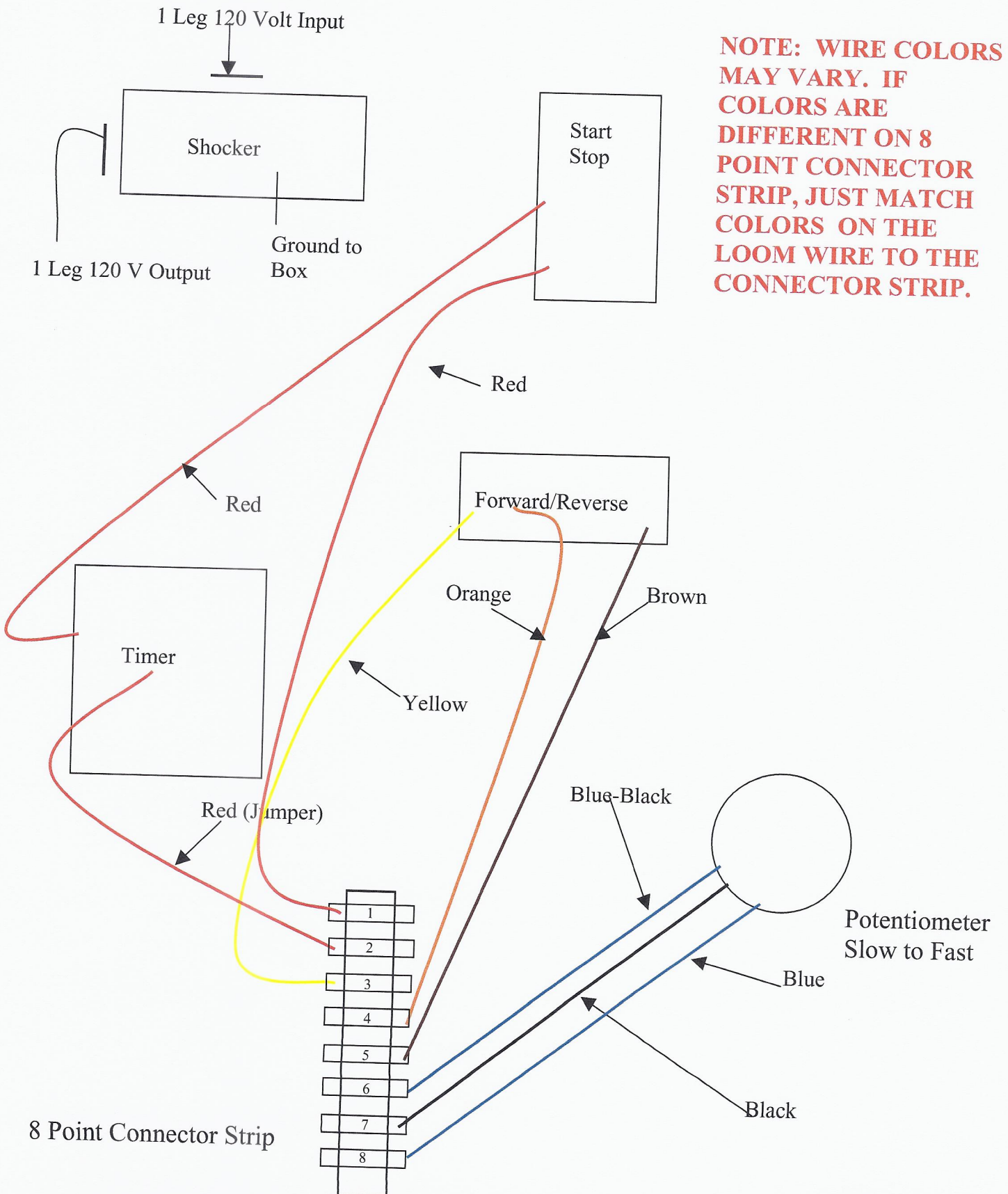
Attached to Frame of  
Exerciser



Match the colors on the 8 pin  
connector strip to the wires in  
the wire loom provided by  
Centaur Horse Walkers, Inc.



# Centaur Equinecisers Control Unit with Timer Wiring Diagram On Backside of Centaur Control Box



# OPERATING INSTRUCTIONS

1. The Equineciser is designed to exercise horses for conditioning and cooling. The variable speed control is provided to allow the option of adjustment of speed for different horses needs.
2. Horses "DO" require training to walk and behave properly on the exerciser. It is not intended to be used to break wild horses or force them to walk.
3. Screens on each arm are furnished with the Equineciser. They should be inspected once a month, they should be replaced immediately, if the electrical contact to the screen begins to fray. The Quick Links and/or the chain should also be inspected at the same time, the quick links and/or chain should be replaced immediately, if they show signs of weakness or breakage.
4. A monthly check and tightening of all bolted parts is needed on all Quick Links, and all nuts & bolts that attach the rubber mat to the screen.
5. Grease – Grease zerks are located on the vertical shaft. These will grease the moving parts of the drive tower. Greasing every 90 to 120 days is recommended. When greasing use Lithium grease only.
6. Any electrical service should be done by a licensed electrician. 220 Volt wiring is required. NEVER adjust Equineciser speed or put hands near drive assembly unless the electrical switch and the breaker box inside the Equineciser is off.
7. Equinecisers are warranted for one year from the date of purchase as per attached warranty statement.



## **“DO’S AND DON’TS”**

<p>DO NOT attempt to use Equineciser prior to being properly secured to the foundation pad.</p> <p>DO NOT leave the Equineciser unattended while in operation.</p> <p>DO NOT open the cabinet to adjust speed or to turn the power off. Turn power off at the remote switch <b>before</b> opening the cabinet.</p> <p>DO NOT operate the Equineciser with the cabinet off.</p> <p>DO NOT put hands or feet near the drive system while the Equineciser is in operation.</p> <p>DO NOT put more than 1 (one) horse or foal in each moving compartment.</p> <p>DO NOT put studs &amp; mares in exerciser at same time.</p> <p>DO NOT turn electrified divider screens <b>ON</b> after horses are in the exerciser.</p> <p>DO NOT ride or allow a child to ride a horse that is being exercised.</p> <p>DO NOT use your Equineciser as a merry-go-round for children or adults.</p>	<p>DO have all electrical hook-ups done by a licensed electrician.</p> <p>DO have electrified divider screens turned <b>ON</b> before &amp; during the loading &amp; unloading of horses.</p> <p>DO accelerate exerciser slowly &amp; de-accelerate slowly, so that the computer is not damaged, and the horses have time to adjust to the speed.</p> <p>DO allow the Equineciser to stop completely before reversing direction.</p> <p>DO check for electrical charge on each divider screen once a month.</p> <p>DO grease your Equineciser at the grease fittings 90-120 days or more often if the unit is in constant use.</p>
--	--

**Use the utmost caution in operating this equipment.**

**DO NOT allow water or moisture to accumulate around any wiring, switches, or the motor.**

**Moving parts can be hazardous to a person wearing loosely fitting clothing or with long hair.**

**All moving parts of this equipment are of heavy gauge steel. DO NOT expose any portion of your body to this equipment while it is in motion.**

**As with all electrical driven equipment, the utmost caution must be taken with regard to exposure to electrical shock caused through a rupture of any electrical connections or wire.**



## Control Box Operating Instructions For Free Flow Equinecisers Timers **ONLY**

1. Turn Power Switch on.
2. Turn on Timer.
  - Minimum setting for timer **MUST** be 10 minutes or more.
3. Turn dial to desired speed.
  - **NOTE:** The Speed Knob is time delayed.
  - **Never turn Timer off.**
4. Use On/Off Switch **ONLY** to turn Equineciser On & Off.
5. **NEVER** turn Timer back to Zero, doing so will critically damage the Equineciser and void your warranty. Always allow Timer to run down on it's own.
6. Equineciser **MUST** come to a complete stop **PRIOR** to switching directions. Failure to do so will critically damage the Equineciser and void your warranty.

**For questions or service call 1-800-962-8050**



## **Centaur Free Flow Equineciser Limited Warranty**

### **Centaur Five-Year Limited Warranty**

**Centaur Horse Walkers, Inc** warrants that for a period of five (5) years after the date of delivery it will re-supply the following component parts: Falk Collar Coupling, and the Drive System (Gearbox, and Motor) (under normal usage) on their Free Flow Equinecisers Models 300FF, 350FF, 400FF, 450FF, 500FF, 550FF, 600FF and 650FF to the original user against defects in workmanship or materials under normal use, with regular service maintenance of the equineciser sold that prove to be defective in respect to the materials and/or workmanship. The warranty is expressly limited to furnishing (but not dismantling or installing) necessary replacement parts, does not cover or include any consequential damages and does not cover defects or damage caused by acts of God, falling objects, or other accidents or casualties, aggressive atmosphere conditions (including, but not limited to, salt water atmosphere, fallout or exposure to corrosive chemicals, fumes, ash, animal waste, excessive wind and excessive snow loading or the like), improper installation, neglect, negligence abuse or willful damage by Purchaser, this includes attaching objects to the screens and/or the arms, to use to level and/or smooth out the exerciser path, & attaching objects to the screens and/or arms, to use as a weather shade. Any defect or damage covered by this warranty must be reported to Centaur, in writing within 30 days after discovery or this warranty shall be void. It is expressly understood and agreed that any warranty, expressed or implied, shall extend only to structural defects in the material, whether galvanized (optional) or steel (standard), and any component parts appurtenant to the equipment. Any part, which is determined by Centaur to be defective in material or workmanship and returned to our authorized service location, as Centaur designates, shipping costs prepaid by client, will be, as the exclusive remedy, repaired or replaced at Centaur's option. Shipping to be supplied by client on all returning items. For limited warranty, claim procedures see PROMPT DISPOSITION below. This limited warranty gives purchasers specific legal rights, which vary, from state to state. THIS WARRANTY IS GIVEN EXPRESSLY AND IN PLACE OF ALL OTHER EXPRESS OR IMPLIED WARRANTIES INCLUDING IMPLIED WARRANTIES OF MERCHANTABILITY AND FITNESS FOR A PARTICULAR PURPOSE.

### **Centaur One-Year Limited Warranty**

**Centaur Horse Walkers, Inc** warrants that for a period of one (1) year after the date of delivery it will re-supply the following component parts: AC Tech Controller and/or ABB Controller, Remote Control Box, Fence Shocker, and Fencing (under normal usage) on their Free Flow Equinecisers Models 300FF, 350FF, 400FF, 450FF, 500FF, 550FF, 600FF and 650FF to the original user against defects in workmanship or materials under normal use, with regular service maintenance of the equineciser sold that prove to be defective in respect to the materials and/or workmanship. The warranty is expressly limited to furnishing (but not dismantling or installing) necessary replacement parts, does not cover or include any consequential damages and does not cover defects or damage caused by acts of God, falling objects, or other accidents or casualties, aggressive atmosphere conditions (including, but not limited to, salt water atmosphere, fallout or exposure to corrosive chemicals, fumes, ash, animal waste, excessive wind and excessive snow loading or the like), improper installation, neglect, negligence abuse or willful damage by Purchaser, this includes attaching objects to the screens and/or the arms, to use to level and/or smooth out the exerciser path, & attaching objects to the screens and/or arms, to use as a weather shade. Any defect or damage covered by this warranty must be reported to **Centaur**, in writing within 30 days after discovery or this warranty shall be void. It is expressly understood and agreed that any warranty, expressed or implied, shall extend only to structural defects in the material, whether galvanized (optional) or steel (standard), and any component parts appurtenant to the equipment. Any part, which is determined by Centaur to be defective in material or workmanship and returned to our authorized service location, as Centaur designates, shipping costs prepaid by client, will be, as the exclusive remedy, repaired or replaced at Centaur's option. Shipping to be supplied by client on all returning items. For limited warranty, claim procedures see PROMPT DISPOSITION below. This limited warranty gives purchasers specific legal rights, which vary, from state to state. THIS WARRANTY IS GIVEN EXPRESSLY AND IN PLACE OF ALL OTHER EXPRESS OR IMPLIED WARRANTIES INCLUDING IMPLIED WARRANTIES OF MERCHANTABILITY AND FITNESS FOR A PARTICULAR PURPOSE.

Mats on the bottom of screens or attached to fence panels do **NOT** come with a warranty. Any part, which is determined by **Centaur** to be defective in material or workmanship and returned to our authorized service location, as **Centaur** designates, shipping costs prepaid by client, will be, as the exclusive remedy, repaired or replaced at **Centaur's** option. Shipping to be supplied by client on all returning items. For limited warranty claim procedures see PROMPT DISPOSITION below. This limited warranty gives purchasers specific legal rights, which vary, from state to state.

Any dispute about quality, condition or workmanship of the goods or otherwise in connection with the terms of this Agreement, shall not entitle the Buyer to reject the goods. In the case of any dispute the Buyer shall take delivery of the goods, pay for the same, and make a claim under the **Centaur's** warranty.

Working Diameter is approximate intended to identify size sold by **Centaur**. Centaur gives no warranty or representation as to exact dimensions of the working diameter, as the same will vary depending upon placement of concrete base.



### **Limitation of Liability**

To the extent allowable under applicable law, **Centaur's** liability for consequential and incidental damages is expressly disclaimed. **Centaur's** liability in all events is limited to, and shall not exceed, the purchase price paid.

### **Warranty Disclaimer**

**Centaur** has made a diligent effort to illustrate and describe the products in this literature accurately; however such illustrations and description are for the sole purpose of identification, and do not express or imply a warranty that the products are merchantable, or fit for a particular purpose, or that the products will necessarily conform to the illustrations or descriptions.

### **Product Suitability**

Many states and localities have codes and regulations governing sales, construction installation and/or use of products for certain purposes, which may vary from those in neighboring areas. While **Centaur** attempts to assure that its products comply with such codes it cannot guarantee compliance and cannot be responsible for how the product is installed or used. Before purchase and use of our products, please review the product application, and national & local codes and regulations, and be sure that the product, installation, and use will comply with them.

Certain aspects of disclaimers are not applicable to consumer products; e.g., (A) some states do not allow the exclusion or limitation of incidental or consequential damages, so the above limitations or warranty lasts, consequently the limitations may not apply to you; (B) Also, some states do not allow limitations on how long an implied warranty lasts, consequently the above limitations may not apply to you; and (C) by law, during the period of the limited warranty any implied warranties of merchantability or fitness for a particular purpose applicable to consumer products purchased by consumer, may not be excluded or otherwise disclaimed.

### **Prompt Disposition**

**Centaur** will in good faith effort for prompt correction or other adjustment with respect to any product, which proves to be defective within limited warranty. For any product believed to be defective within limited warranty, first write or call dealer from whom product was purchased. Dealer will be given additional directions. If unable to resolve satisfactorily write to **Centaur Horse Walkers, Inc.** 5761 Ridgeview Ave., Mira Loma, Ca. 91752, giving dealer's name, address, date and number of dealer's invoice, and describing the nature of the defect. Title and risk of loss pass to buyer on delivery to common carrier. If product was damaged in transit you, file claim with freight carrier.



## **MAINTENANCE & LUBRICATION SCHEDULE**

**NOTE:** Remove the entire cover for easy service, which is made up of 4 individual panels.

**Fenner Transtorque tightening collar see page**

**Falk Steelflex Couplings see page**

**Nord Drive System see page**

**2 Pillow Block units on vertical shaft see page**

### **PILLOW BLOCK MAINTENANCE:**

Use standard bearing grease to lube the 2 units on the vertical shaft. Lube at least every 90 days with a standard grease gun.

### **REPLACEMENT PARTS:**

Any parts that become worn or broken can be replaced by calling our Corporate Offices at 1-800-962-8050 or 951-685-7337. Most of the parts can be shipped the same day.

For all remote control units, motors, switches, vari-pulleys, and gearboxes all the model numbers are located on their I.D. plates, for ordering.

### How To Use This Manual

This manual provides detailed instructions on maintenance, lubrication, installation, and parts identification. Use the table of contents below to locate required information.

### Table of Contents

Introduction . . . . .	Page 1
Lube Fittings . . . . .	Page 1
Limited End Float . . . . .	Page 1
Lubrication . . . . .	Pages 1-2
Installation & Alignment Instructions . . . . .	Pages 2-4
Annual Maintenance, Relube & Disassembly . . . . .	Page 4
Installation & Alignment Data . . . . .	Page 5
Parts Identification & Parts Interchangeability . . . . .	Page 6

**CAREFULLY FOLLOW THE INSTRUCTIONS IN THIS MANUAL FOR OPTIMUM PERFORMANCE AND TROUBLE FREE SERVICE.**

### INTRODUCTION

This manual applies to Sizes 1020T thru 1140T and 20T thru 140T10 Falk Steelflex Tapered Grid Couplings. Unless otherwise stated, information for Sizes 1020T thru 1140T applies to Sizes 20T thru 140T respectively, e.g. 1020T = 20T, 1100T = 100T, etc. These couplings are designed to operate in either the horizontal or vertical position without modification. Beginning in 1994, these couplings are being supplied with one set of inch series fasteners and one set of metric fasteners. Use either set of fasteners, depending on your preference. Refer to Page 6 for part interchangeability.

The performance and life of the couplings depend largely upon how you install and service them.

**CAUTION:** Consult applicable local and national safety codes for proper guarding of rotating members. Observe all safety rules when installing or servicing couplings.

**WARNING:** Lockout starting switch of prime mover and remove all external loads from drive before installing or servicing couplings.

### LUBE FITTINGS

Cover halves have 1/8 NPT lube holes. Use a standard grease gun and lube fitting as instructed on Page 4.

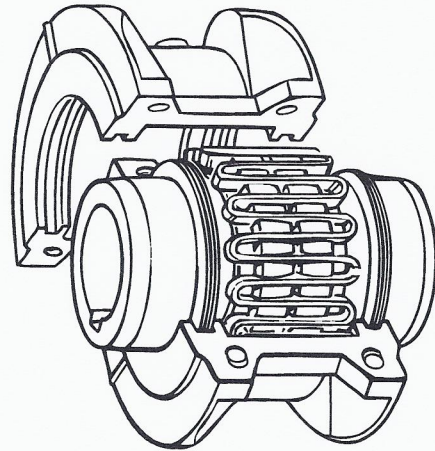
### LIMITED END FLOAT

When electric motors, generators, engines, compressors and other machines are fitted with sleeve or straight roller bearings, limited axial end float kits are recommended for protecting the bearings. Falk Steelflex couplings are easily modified to limit end float; refer to Manual 428-820 for instructions.

### LUBRICATION

Adequate lubrication is essential for satisfactory operation. Page 2 provides a list of typical lubricants and specifications for general purpose and long term greases. Because of its superior lubricating characteristics and low centrifuge properties, Falk Long Term Grease (LTG) is highly

### TYPE T10 STEELFLEX COUPLING



recommended. Sizes 1020T to 1090T10 are furnished with a pre-measured amount of grease for each coupling. The grease can be ordered for larger size couplings.

The use of general purpose grease requires re-lubrication of the coupling at least annually.

### Long Term Grease (LTG)

The high centrifugal forces encountered in couplings separate the base oil and thickener of general purpose greases. Heavy thickener, which has no lubrication qualities, accumulates in the grid-groove area of Steelflex couplings resulting in premature hub or grid failure unless periodic lubrication cycles are maintained.

Falk Long Term Grease (LTG) was developed specifically for couplings. It resists separation of the oil and thickener. The consistency of Falk LTG changes with operating conditions. As manufactured it is an NLGI #1/2 grade. Working of the lubricant under actual service conditions causes it to become semifluid while the grease near the seals will set to a heavier grade, helping to prevent leakage.

LTG is highly resistant to separation, easily out performing all other lubricants tested. The resistance to separation allows the lubricant to be used for relatively long periods of time.

Steelflex couplings initially lubricated with LTG will not require re-lubrication until the connected equipment is stopped for servicing. If a coupling leaks grease, is exposed to extreme temperatures, excessive moisture, or experiences frequent reversals, more frequent lubrication may be required.

Although LTG grease is compatible with most other coupling greases, the mixing of greases may dilute the benefits of LTG.

### USDA Approval

LTG has the United States Department of Agriculture Food Safety & Inspection Service approval for applications where there is no possibility of contact with edible products. (H-2 ratings).

**CAUTION:** Do not use LTG in bearings.



### Specifications — Falk LTG

The values shown are typical and slight variations are permissible.

AMBIENT TEMPERATURE RANGE — -20°F (-29°C) to 250°F (121°C). Min. Pump = 20° F (-7° C).

MINIMUM BASE OIL VISCOSITY — 3300SSU (715cST) @ 100°F (38°C).

THICKENER — Lithium & soap/polymer.

CENTRIFUGE SEPARATION CHARACTERISTICS — ASTM #D4425 (Centrifuge Test) — K36 = 2/24 max., very high resistance to centrifuging.

NLGI GRADE (ASTM D-217) — 1/2

MINIMUM DROPPING POINT — with 60 stroke worked penetration value in the range of 320 to 365 — 350°F (177°C) min.

MINIMUM TIMKEN O.K. LOAD — 40 lbs.

ADDITIVES — Rust and oxidation inhibitors that do not corrode steel or swell or deteriorate synthetic seals.

### Packaging

14 oz. (0,4 kg ) CARTRIDGES — Individual or case lots of 10 or 60.

35 lb. (16 kg )PAIL, 120 lb. (54 kg ) KEG & 400 lb. (181 kg) DRUMS.

### General Purpose Grease

Annual Lubrication — The following specifications and lubricants for general purpose grease apply to Falk Steelflex couplings that are lubricated annually and operate within ambient temperatures of 0°F to 150°F (-18°C to 66°C). For temperatures beyond this range (see Table 1), consult the Factory.

If a coupling leaks grease, is exposed to extreme temperatures, excessive moisture or experiences frequent reversals, more frequent lubrication may be required.

### Specifications — General Purpose Coupling Lubricants

The values shown are typical and slight variations are permissible.

DROPPING POINT — 300°F (149°C) or higher.

CONSISTENCY — NLGI No. 2 with 60 stroke worked penetration value in the range of 250 to 300.

SEPARATION AND RESISTANCE — Low oil separation rate and high resistance to separation from centrifuging.

LIQUID CONSTITUENT — Possess good lubricating properties equivalent to a high quality, well refined petroleum oil.

INACTIVE — Must not corrode steel or cause swelling or deterioration of synthetic seals.

CLEAN — Free from foreign inclusions.

### General Purpose Greases Meeting Falk Specifications

Lubricants listed below are typical products only and should not be construed as exclusive recommendations.

TABLE 1 — General Purpose Greases

Ambient Temperature Range	0°F to 150°F (-18°C to 66°C)	-30°F to 100°F (-34°C to 38°C)
Manufacturer	Lubricant †	Lubricant †
Amoco Oil Co.	Amolith Grease #2	Amolith Grease #2
BP Oil Co.	Energrease LS-EP2	Energrease LS-EP1
Chevron U.S.A. Inc.	Dura-Lith EP2	Dura-Lith EP1
Citgo Petroleum Corp.	Premium Lithium Grease EP2	Premium Lithium Grease EP1
Conoco Inc.	EP Conolith Grease #2	EP Conolith Grease #2
Exxon Company, USA	Unirex N2	Unirex N2
E.F. Houghton & Co.	Cosmolube 2	Cosmolube 1
Imperial Oil Ltd.	Unirex N2L	Unirex N2L
Kendall Refining Co.	Lithium Grease L421	Lithium Grease L421
Keystone Div. (Pennwalt)	81 EP-2	81 EP-1
Lyondell Petrochemical (ARCO)	Litholine H EP 2 Grease	Litholine H EP 2 Grease
Mobil Oil Corp.	Mobilux EP111	Mobilith AW1
Petro-Canada Products	Multipurpose EP2	Multipurpose EP1
Phillips 66 Co.	Philube Blue EP	Philube Blue EP
Shell Oil Co.	Alvania Grease 2	Alvania Grease 2
Shell Canada Ltd.	Alvania Grease 2	Alvania Grease 2
Sun Oil Co.	Ultra Prestige 2EP	Ultra Prestige 2EP
Texaco Lubricants	Starplex HD2	Multifak EP2
Unocal 76 (East & West)	Unoba EP2	Unoba EP2
Valvoline Oil Co.	Multilube Lithium EP Grease	...

★ Grease application or re-lubrication should be done at temperatures above 20°F (-7°C). If grease must be applied below 20°F (-7°C), consult The Falk Corporation.

† Lubricants listed may not be suitable for use in the food processing industry; check with lube manufacturer for approved lubricants.

### INSTALLATION OF TYPE T10 STEELFLEX TAPERED GRID COUPLINGS

#### Installation

Only standard mechanics tools, wrenches, a straight edge and feeler gauges are required to install Falk Steelflex couplings. Coupling Sizes 1020T thru 1090T are generally furnished for CLEARANCE FIT with setscrew over the keyway. Sizes 1100T and larger are furnished for an INTERFERENCE FIT without a setscrew.

CLEARANCE FIT HUBS — Clean all parts using a non-flammable solvent. Check hubs, shafts and keyways for burrs. Do not heat clearance fit hubs. Install keys, mount hubs with flange face flush with shaft ends or as otherwise specified and tighten setscrews.

INTERFERENCE FIT HUBS — Furnished without setscrews. Heat hubs to a maximum of 275°F (135°C) using an oven, torch, induction heater or an oil bath. To prevent seal damage, DO NOT heat hubs beyond a maximum temperature of 400°F (205°C).

When an oxy-acetylene or blow torch is used, use an excess acetylene mixture. Mark hubs near the center of their length in several places on hub body with a temperature sensitive crayon, 275°F (135°C) melt temperature. Direct flame towards hub bore using constant motion to avoid overheating an area.



**WARNING:** If an oil bath is used, the oil must have a flash point of 350°F (177°C) or higher. Do not rest hubs on the bottom of the container. Do not use an open flame in a combustible atmosphere or near combustible materials.

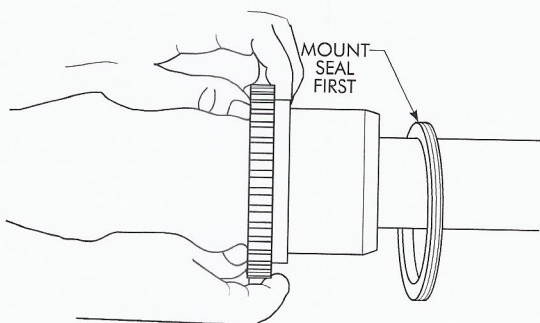
Heat hubs as instructed above. Mount hubs as quickly as possible with hub face flush with shaft end. Allow hubs to cool before proceeding. Insert setscrews (if required) and tighten.

### Maximize Performance And Life

The performance and life of couplings depend largely upon how you install and maintain them. Before installing couplings, make certain that foundations of equipment to be connected meet manufacturers' requirements. Check for soft foot. The use of stainless steel shims is recommended. Measuring misalignment and positioning equipment within alignment tolerances is simplified with an alignment computer. These calculations can also be done graphically or mathematically.

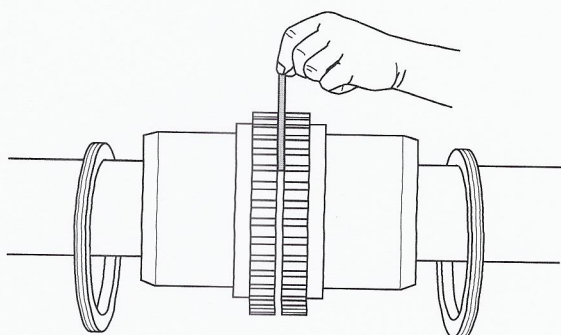
Alignment is shown using spacer bar and straight edge. This practice has proven to be adequate for many industrial applications. However, for superior final alignment, the use of dial indicators (see Manual 458-834 for instructions), lasers, alignment computers or graphical analysis is recommended.

#### 1 — Mount Seals And Hubs



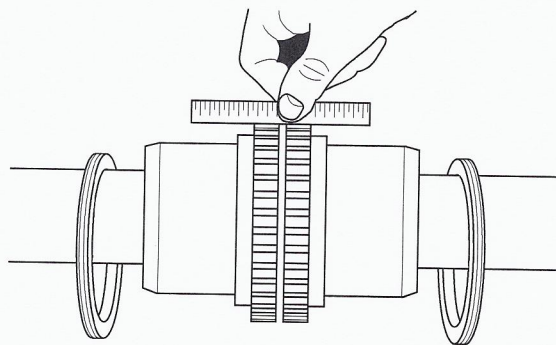
Lock out starting switch of prime mover. Clean all metal parts using a non-flammable solvent. Lightly coat seals with grease and place on shafts BEFORE mounting hubs. Heat interference fit hubs as previously instructed. Seal keyways to prevent leakage. Mount hubs on their respective shafts so the hub face is flush with the end of its shaft unless otherwise indicated. Tighten setscrews when furnished.

#### 2 — Gap and Angular Alignment



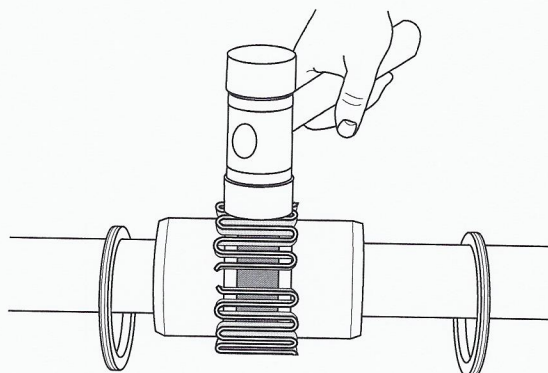
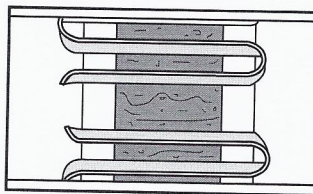
Use a spacer bar equal in thickness to the gap specified in Table 2, Page 5. Insert bar as shown below left, to same depth at 90° intervals and measure clearance between bar and hub face with feelers. The difference in minimum and maximum measurements must not exceed the ANGULAR installation limits specified in Table 2.

#### 3 — Offset Alignment



Align so that a straight edge rests squarely (or within the limits specified in Table 2) on both hubs as shown above and also at 90° intervals. Check with feelers. The clearance must not exceed the PARALLEL OFFSET installation limits specified in Table 2. Tighten all foundation bolts and repeat Steps 2 and 3. Realign coupling if necessary.

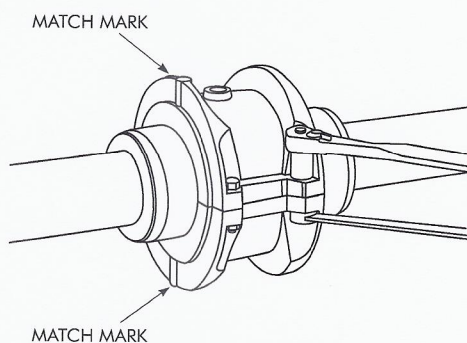
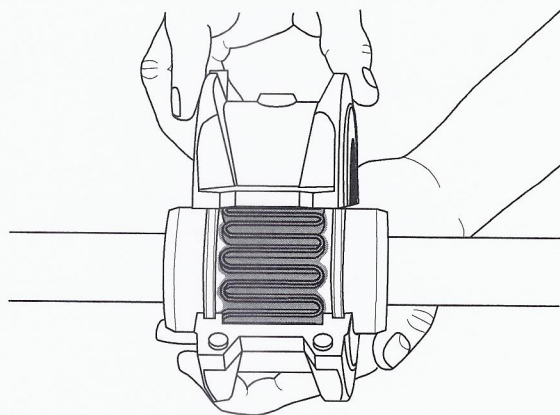
#### 4 — Insert Grid



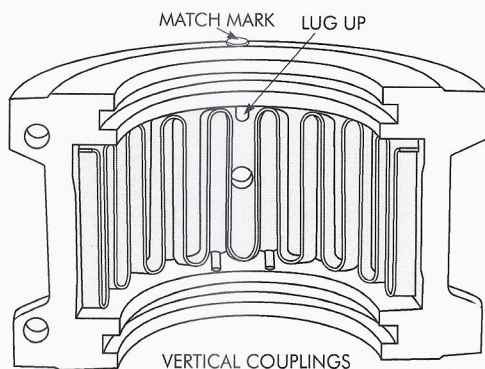
Pack gap and grooves with specified lubricant before inserting grid. When grids are furnished in two or more segments, install them so that all cut ends extend in the same direction (as detailed in the exploded view picture above); this will assure correct grid contact with non-rotating pin in cover halves. Spread the grid slightly to pass over the coupling teeth and seat with a soft mallet.



### 5 — Pack With Grease And Assemble Covers



Pack the spaces between and around the grid with as much lubricant as possible and wipe off excess flush with top of grid. Position seals on hubs to line up with grooves in cover. Position gaskets on flange of lower cover half and assemble covers so that the match marks are on the same side (see above). If shafts are not level (horizontal) or coupling is to be used vertically, assemble cover halves with the lug and match mark



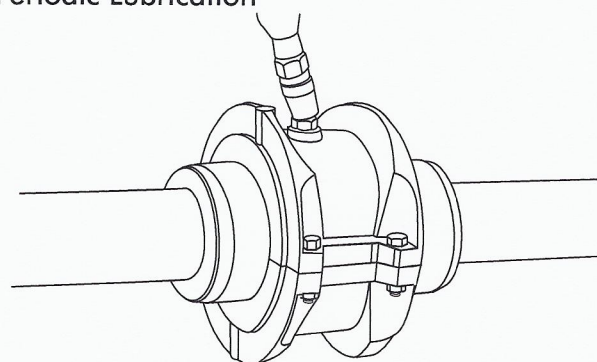
UP or on the high side. Push gaskets in until they stop against the seals and secure cover halves with fasteners, tighten to torque specified in Table 2. Make sure gaskets stay in position during tightening of fasteners. **CAUTION:** Make certain lube plugs are installed before operating.

### ANNUAL MAINTENANCE

For extreme or unusual operating conditions, check coupling more frequently.

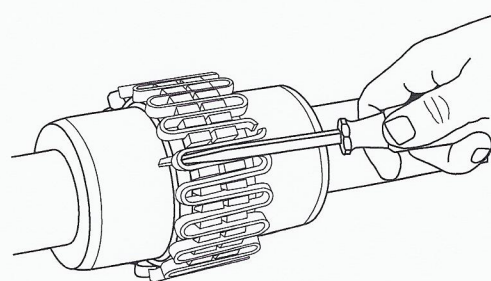
1. Check alignment per steps on Page 3. If the maximum operating misalignment limits are exceeded, realign the coupling to the recommended installation limits. See Table 2 for installation and operating alignment limits.
2. Check tightening torques of all fasteners.
3. Inspect seal ring and gasket to determine if replacement is required. If leaking grease, replace.
4. When connected equipment is serviced, disassemble the coupling and inspect for wear. Replace worn parts. Clean grease from coupling and repack with new grease. Install coupling using new gasket as instructed in this manual.

### Periodic Lubrication



The required frequency of lubrication is directly related to the type of lubricant chosen, and the operating conditions. Steelflex couplings lubricated with common industrial lubricants, such as those shown in Table 1, should be relubed annually. The use of Falk Long Term Grease (LTG) will allow relube intervals to be extended to beyond five years. When relubing, remove both lube plugs and insert lube fitting. Fill with recommended lubricant until an excess appears at the opposite hole. **CAUTION:** Make certain all plugs have been inserted after lubricating.

### Coupling Disassembly And Grid Removal



Whenever it is necessary to disconnect the coupling, remove the cover halves and grid. A round rod or screwdriver that will conveniently fit into the open loop ends of the grid is required. Begin at the open end of the grid section and insert the rod or screwdriver into the loop ends. Use the teeth adjacent to each loop as a fulcrum and pry the grid out radially in even, gradual stages, proceeding alternately from side to side.



### TYPE T COUPLING INSTALLATION & ALIGNMENT DATA

Maximum life and minimum maintenance for the coupling and connected machinery will result if couplings are accurately aligned. Coupling life expectancy between initial alignment and maximum operating limits is a function of load, speed and lubrication. Maximum operating values listed in Table 2 are based on cataloged allowable rpm.

Values listed are based upon the use of the gaps listed, standard coupling components, standard assemblies and cataloged allowable speeds.

Values may be combined for an installation or operating condition.

Example: 1060T max. operating misalignment is .016" parallel plus .018" angular.

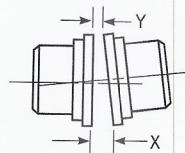
NOTE: For applications requiring greater misalignment, refer application details to Falk.

Angular misalignment is dimension X minus Y as illustrated below.

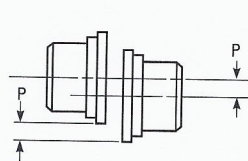
Parallel misalignment is distance P between the hub center lines as illustrated below.

End float (with zero angular and parallel misalignment) is the axial movement of the hubs(s) within the cover(s) measured from "O" gap.

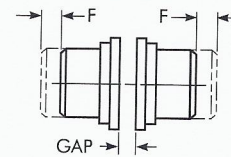
ANGULAR MISALIGNMENT



PARALLEL OFFSET MISALIGNMENT



END FLOAT



### TABLE 2 — Misalignment & End Float

SIZE	Installation Limits						Operating Limits						Cover Fastener Tightening Torque Values		Allow Speed (rpm)	Lube Wt	
	Parallel Offset-P		Angular (x-y)		Hub Gap ± 10%		Parallel Offset-P		Angular (x-y)		End Float Physical Limit (Min) 2 x F						
	Max Inch	Max mm	Max Inch	Max mm	Inch	mm	Max Inch	Max mm	Max Inch	Max mm	Inch	mm	In Series Fasteners (lb-in)	Metric Fasteners (Nm)		lb	kg
1020T	.006	0.15	.003	0.08	.125	3	.012	0.30	.010	0.25	.210	5.33	100	11.3	4500	.06	0.03
1030T	.006	0.15	.003	0.08	.125	3	.012	0.30	.012	0.30	.198	5.03	100	11.3	4500	.09	0.04
1040T	.006	0.15	.003	0.08	.125	3	.012	0.30	.013	0.33	.211	5.36	100	11.3	4500	.12	0.05
1050T	.008	0.20	.004	0.10	.125	3	.016	0.41	.016	0.41	.212	5.38	200	23.6	4500	.15	0.07
1060T	.008	0.20	.005	0.13	.125	3	.016	0.41	.018	0.46	.258	6.55	200	23.6	4350	.19	0.09
1070T	.008	0.20	.005	0.13	.125	3	.016	0.41	.020	0.51	.259	6.58	200	23.6	4125	.25	0.11
1080T	.008	0.20	.006	0.15	.125	3	.016	0.41	.024	0.61	.288	7.32	200	23.6	3600	.38	0.17
1090T	.008	0.20	.007	0.18	.125	3	.016	0.41	.028	0.71	.286	7.26	200	23.6	3600	.56	0.25
1100T	.010	0.25	.008	0.20	.188	5	.020	0.51	.033	0.84	.429	10.90	312	35	2440	.94	0.43
1110T	.010	0.25	.009	0.23	.188	5	.020	0.51	.036	0.91	.429	10.90	312	35	2250	1.1	0.51
1120T	.011	0.28	.010	0.25	.250	6	.022	0.56	.040	1.02	.556	14.12	650	73	2025	1.6	0.74
1130T	.011	0.28	.012	0.30	.250	6	.022	0.56	.047	1.19	.551	14.00	650	73	1800	2.0	0.91
1140T	.011	0.28	.013	0.33	.250	6	.022	0.56	.053	1.35	.571	14.50	650	73	1650	2.5	1.14

### TABLE 3 — Coupling Cover Fastener Identification

SIZE	Inch Series Fasteners				METRIC FASTENERS	
	Old Style		New Style			
1020-1070T10		SAE Grade 8 ★		SAE Grade 8		Property Class 10.9
1080-1090T10		SAE Grade 8		SAE Grade 8		Property Class 10.9
1100-1140T10		SAE Grade 5		SAE Grade 5		Property Class 8.8

★ Older style covers, Sizes 1020T10 thru 1070T10 must utilize socket head cap screws and locknuts held by the cover.



### PARTS IDENTIFICATION

All coupling parts have identifying part numbers as shown below. Parts 3 and 4 (Hubs and Grids), are the same for both Type T10 and T20 couplings. All other coupling parts are unique to Type T10. When ordering parts, always SPECIFY SIZE and TYPE shown on the COVER.

### PARTS INTERCHANGEABILITY

Parts are interchangeable between Sizes 20T and 1020T, 30T and 1030T, etc. except as noted.

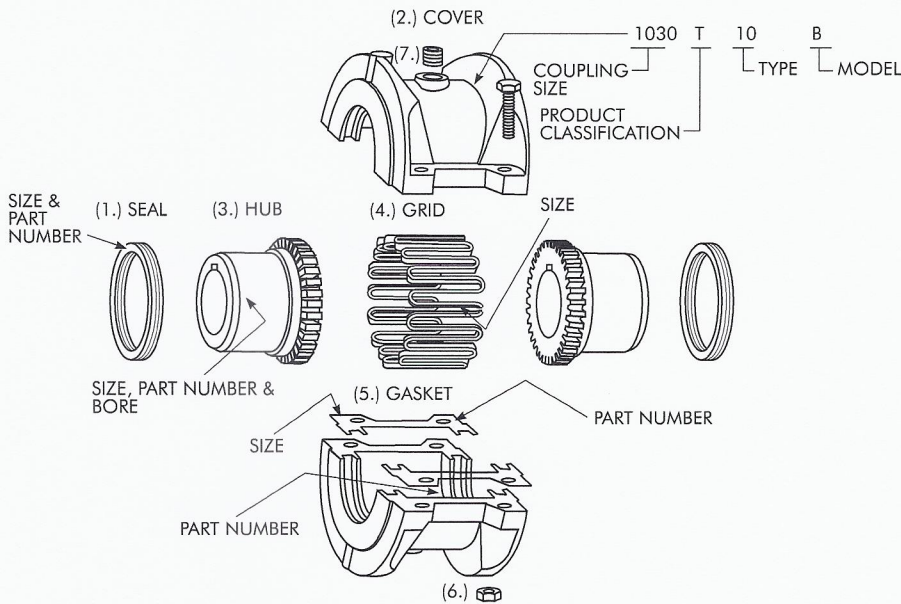
GRIDS — Size 1020T thru 1140T Steelflex couplings use blue grids. Older models, 20T thru 140T, use orange grids.

**CAUTION:** Blue grids may be used in all applications, but DO NOT substitute orange grids for blue.

**COVERS — CAUTION:** DO NOT mix cover halves of different designs. Sizes 1020T thru 1070T10 covers have been manufactured in several different two-rib designs and 80T thru 140T covers have been manufactured with two and three ribs.

**HARDWARE —** Older style covers, Sizes 1020T10 thru 1070T10, utilized socket head cap screws with captured locknuts. The new style covers use hex head cap screws (either inch or metric) and unrestrained locknuts. Specify either inch series SOCKET head or metric series HEX head cap screws when ordering replacement parts.

### PART NUMBER LOCATION



### PART DESCRIPTION

1. Seal (T10)
2. Cover (T10)
3. Hub (Specify bore and keyway)
4. Grid
5. Gasket (T10)
6. Fasteners (T10) — Coupling may be supplied with one set each of inch series fasteners and metric fasteners.
7. Lube Plug

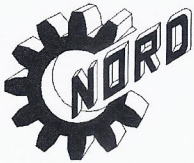
### ORDER INFORMATION

1. Identify part(s) required by name above.
2. Furnish the following information.

**EXAMPLE:**

**Coupling Size:** 1030  
**Coupling Type:** T10  
**Model:** B  
**Bore:** 1.375  
**Keyway:** .375 x .187

3. Price parts from Price List 422-110 and appropriate discount sheet.



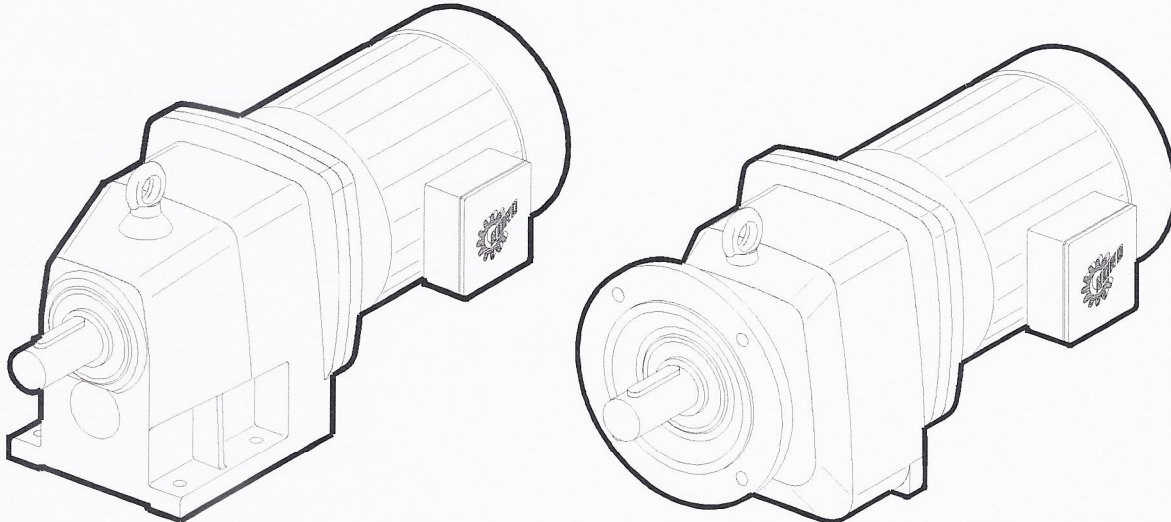
# UNICASE<sup>®</sup> Helical Inline Gearboxes Installation and Maintenance Instructions

BIM 1010

USA

CDN

Retain These Safety Instructions For Future Use



## INSPECTION OF UNIT

Thoroughly inspect the equipment for any shipping and handling damage before accepting shipment from the freight company. If any of the goods called for in the bill of lading or express receipt are damaged or the quantity is short, do not accept until the freight or express agent makes an appropriate notation on your freight bill or express receipt. If any concealed loss or damage is discovered later, notify your freight carrier or express agent at once and request him to make an inspection. We will be very happy to assist you in collecting claims for loss or damage during shipment; however, this willingness on our part does not remove the transportation company's responsibility in reimbursing you for collection of claims or replacement of material. Claims for loss or damage in shipment must not be deducted from the NORD Gear invoice, nor should payment of the NORD Gear invoice be withheld awaiting adjustment of such claims, as the carrier guarantees safe delivery.

If considerable damage has been incurred and the situation is urgent, contact the nearest NORD Gear Sales Office for assistance. Please keep a written record of all communications.

## RECORD NAMEPLATE DATA

Locate the gear reducer nameplate and record all nameplate data for future reference.

SK \_\_\_\_\_ S/N \_\_\_\_\_  
RATIO \_\_\_\_\_ MAX TORQUE \_\_\_\_\_ RPM \_\_\_\_\_ MTG. POS \_\_\_\_\_

## STORAGE

### PROPER STORAGE UNTIL INSTALLED

Keep unit in a dry, temperature controlled area. If stored other than said, long term storage methods must be applied to the unit including complete fill with lubricant. Protect machined surfaces and rotate shafts periodically. Prior to putting unit into service, drain lubricant and refill to proper level as determined by the mounting position.

### PROPER HANDLING OF THE UNIT

Exercise care to prevent damage to the unit when moving. Lift only at designed lifting points. Do not attach other machinery and lift by the unit lifting points. The lifting points are to be used to lift the unit only. Insure that adequate safety measures are taken to protect personnel during transportation. Protect the mounting surface from damage.



### LOCATION

Coupling hubs should be mounted flush with the shaft ends, unless specifically ordered for overhung mounting. Pinions, sprockets and sheaves should be mounted as close as possible to the unit housing to minimize bearing loads and shaft deflections.

### COUPLING ALIGNMENT

Shaft couplings should be installed according to the coupling manufacturer's recommendations for gap, angular and parallel alignment. In many installations, it is necessary to allow for thermal and mechanical shaft movement when determining shaft alignment. The coupling manufacturer's recommendations should be followed.

### AXIAL DISPLACEMENT

The gap between shaft ends should be the same as the specified coupling gap unless overhung mounting of the coupling hub is specified. The coupling gap and shaft gap must be sufficient to accommodate any anticipated thermal or mechanical axial movement.

### ANGULAR ALIGNMENT

Insert a spacer or shim stock equal to the required coupling gap between the coupling hub faces and measure the clearance using feeler gauges. Repeat this at the same depth at 90-degree intervals to determine the amount of angular misalignment.

### PARALLEL ALIGNMENT

Mount a dial indicator to one coupling hub, and rotate this hub, sweeping the outside diameter of the other hub. The parallel misalignment is equal to one-half of the total indicator reading. Another method is to rest a straight edge squarely on the outside diameter of the hubs at 90-degree intervals and measure any gaps with feeler gauges. The maximum gap measurement is the parallel misalignment.

### CHECKING ALIGNMENT

After both angular and parallel alignments are within specified limits, tighten all foundation bolts securely and repeat the above procedure to check alignment. If any of the specified limits for alignment are exceeded, realign the coupling.

### SPROCKET OR SHEAVE ALIGNMENT

Align the sheaves or sprockets square and parallel by placing a straight edge across their faces. Alignment of bushed sheaves and sprockets should be checked after bushings have been tightened. Check horizontal shaft alignment by placing a level vertically against the face of the sheave or sprocket. Adjust belt or chain tension per the manufacturer's specified procedure.

### OUTBOARD PINION ALIGNMENT

Align the pinion by adjusting the gear tooth clearance according to the manufacturer's recommendations and checking for acceptable outboard pinion tooth contact. The foundation bolts may have to be loosened and the unit moved slightly to obtain this contact. When the unit is moved to correct tooth contact, the prime mover should be realigned.

### RECHECK ALIGNMENT

After a period of operation, recheck alignment and adjust as required.

1. Properly install unit on a rigid foundation
  - adequately supported
  - securely bolted into place
  - leveled so as not to distort the gear case
2. Properly install couplings suitable for the application and connected equipment.
3. Ensure accurate alignment with other equipment.
4. Furnish and install adequate machinery guards as needed to protect operating personnel and as required by the applicable standards of the Occupational Safety and Health Administration (OSHA), and by other applicable safety regulations;

5. Ensure that driving equipment is running in the correct direction before coupling to reducers with backstops (designed to operate only in a specific direction) or machinery designed to operate only in one direction.

### CHANGES IN PERFORMANCE SPECIFICATIONS

Owner has the responsibility to consult with NORD GEAR if such items such as applied loads, operating speeds or other operating conditions have changed.



### WARNING:

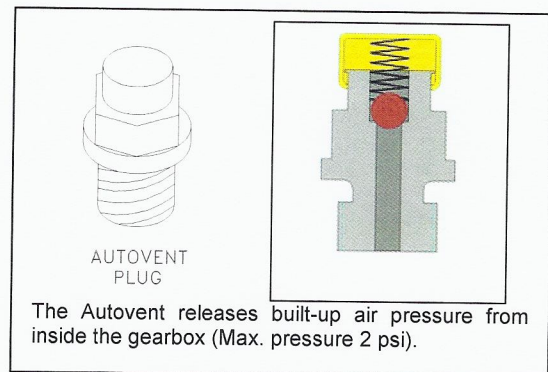
LOCK OUT POWER before any maintenance is performed. Make absolutely sure that no voltage is applied while work is being done on the gearbox.

### START-UP

1. Ensure that switches, alarms, heaters, coolers and other safety and protection devices are installed and operational for their intended purpose.
2. Verify that the installed mounting position is the same as the nametag mounting position. If not, adjust the oil level accordingly and relocate the vent plug, fill plug and drain plug according to the mounting position. See following.

### AUTOVENT PLUG

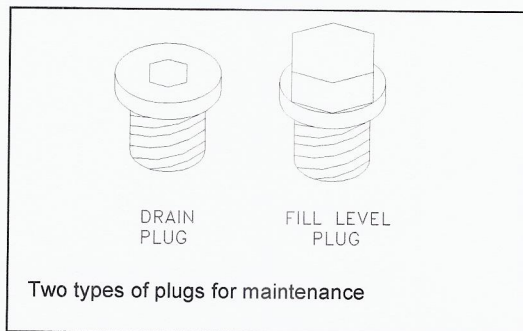
The Autovent plug is brass in color and will be located at the highest point on the gearbox. It operates like a check-valve to allow the reducer to relieve internal pressure while preventing lubricant contamination during cooling. A spring presses a ball or plunger against a machined orifice until pressure exceeds 2 psi. Above 2 psi the air is allowed to escape depressurizing the gearcase. When internal pressure drops below 2 psi, the autovent re-seals closing the unit to the outside environment. After shutdown, the reducer cools along with the air inside the reducer. The unit will temporarily maintain a slight vacuum until normalization occurs. NORD Gear supplies an Autovent as a standard feature.





### FILL LEVEL & DRAIN PLUGS

The drain plugs are metric socket head cap screws. They will be located at the lowest part of the gearbox for ease of draining. The fill level plug is a hex head cap screw. It will be located between the Autovent and drain plug. Both types of plugs will have gaskets included to prevent oil from leaking.



### LUBRICANT

All NORD reducers are shipped from the factory properly filled with lubricant and all plugs are installed according to the mounting position given on the reducer nametag. Acceptable oil fill level is within ½ inch of the bottom of the fill plug threads.

### OPERATION AND MAINTENANCE CHECKLIST

1. Operate the equipment as it was intended to be operated.
2. Do not overload.
3. Run at correct speed.
4. Maintain lubricant in good condition and at proper level.
5. Dispose of used lubricant in accordance with applicable laws and regulations.
6. Apply proper maintenance to attached equipment at prescribed intervals recommended by the manufacturer.
7. Perform periodic maintenance of the gear drive as recommended by NORD.

## MAINTENANCE

Mineral lubricant should be changed every 10,000 service hours or after two years. For synthetic oils, the lube should be changed every 20,000 service hours or after four years. In case of extreme operating (e.g. high humidity, aggressive environment or large temperature variations), shorter intervals between changes are recommended.

### OIL SPECIFICATIONS

NORD supplies all reducers filled with oil from the factory. Consult the sticker adjacent to the fill plug to determine the type of lubricant installed at the factory. Standard lubricant is ISO VG220 mineral-based oil. However, some units have special lubricants designed to operate in certain environments or to extend the service life of the lubricant. If in doubt about which lubricant is needed, contact NORD Gear.

#### STANDARD OIL – ISO VG220

Ambient Temperature	Formulation
20 to 104°F (-5 to 40°C)	Mineral

#### TYPICAL OILS

Viscosity ISO NLGI	Formulation	Service Temperature Range	Mobil®	Shell	Castrol	KLÜBER LUBRICATION	bp	Tribol®
VG 460	Conventional Mineral	20°C to +50°C 68F to +122°F	Mobilgear 634	Omala 460	7EP	Klüberoil GEM 1-460	Energol GR-XP 460	Tribol 1100/460
	Synthetic PAO	-30°C to +80°C -22°F to +176°F	Mobil SHC 634	Omala 460 HD	Isolube EP 460	Klübersynth EG 4-460	N/A	Tribol 1510/460
VG 320	Conventional Mineral	0°C to +30°C 32°F to +86°F	Mobilgear 632	Omala 320	6EP	Klüberoil GEM 1-320	Energol GR-XP 320	Tribol 1100/320
	Synthetic PAO	-35°C to +80°C -31°F to +176°F	Mobil SHC 632	Omala 320 HD	Isolube EP 460	Klübersynth EG 4-320	N/A	Tribol 1510/320
VG 220	Conventional Mineral	-5°C to +40°C +20°F to +104°F	Mobilgear 630	Omala 220	5EP	Klüberoil GEM 1-220	Energol GR-XP 220	Tribol 1100/220
	Synthetic PAO	-34°C to +80°C -30°F to +176°F	Mobil SHC 630	Omala 220 HD	Isolube EP 220	Klübersynth EG 4-220	N/A	Tribol 1510/220
VG 150 & VG 100	Conventional Mineral	-15°C to +25°C 5°F to +77°F	Mobilgear 629	Omala 100	4EP	Klüberoil GEM 1-150	Energol GR-XP 100	Tribol 1100/100
	Synthetic PAO	-37°C to +10°C -35°F to +50°F	Mobil SHC 629	Omala 150 HD	Isolube EP 150	Klübersynth EG 4-150	N/A	N/A
VG 68	Conventional Mineral	-15°C to +25°C 5°F to +77°F	Mobilgear 626	Omala 68	2EP	Klüberoil GEM 1-68	Energol GR-XP 68	Tribol 1100/68
	Synthetic PAO	-40°C to +10°C -40°F to +50°F	Mobil SHC 626	N/A	Isolube EP 68	N/A	N/A	N/A
VG 32	Synthetic PAO	-40°C to +10°C -40°F to +50°F	Mobil SHC 624	N/A	N/A	Klüber-Summit HySyn FG-32	N/A	N/A

PAO = Poly Alpha Olefin

#### SPECIAL PURPOSE LUBRICANTS

Ambient Temperature	Formulation	Manufacturer	Oil Brand Name
20 to 104°F (-5 to 40°C)	Food Grade Oil - Synthetic	Chevron	FM ISO 220
20 to 104°F (-5 to 40°C)	Food Grade Oil - Synthetic	OilJAX	Magnaplate 85W/140-FG
5 to 125°F (-20 to 50°C)	Fluid Grease	Mobil	Mobilux EP023
-30 to 140°F (-35 to 60°C)	Fluid Grease - Synthetic	Mobil	Mobilith SHC 007
-30 to 140°F (-35 to 60°C)	Fluid Grease - Synthetic	Shell	Albida LC

#### STANDARD BEARING GREASE – NLGI 2EP Lithium

Ambient Temperature	Formulation
-20 to 140°F (-30 to 60°C)	Mineral

#### OPTIONAL BEARING GREASES

Ambient Temperature	Formulation	Manufacturer	Grease Brand Name
-40 to 230°F (-40 to 110°C)	Synthetic	Shell	Aeroshell 6
-40 to 230°F (-40 to 110°C)	Food Grade - Synthetic	Lubriplate	SFL1



**LUBRICANT CAPACITY**

Each reducer has the oil level and oil quantity adjusted according to the mounting position shown in the tables. When replacing the oil, consult the tables below to determine the proper amount of oil to be installed according to the reducer size and mounting position. Note that this is approximate and the final level will be adjusted when the reducer is installed. Acceptable oil fill level is within 1/2 inch of the bottom of the fill plug threads.

<b>LUBRICATION CAPACITY – HELICAL INLINE GEARBOXES</b>													
Mounting position		Horizontal position								Vertical position			
		single reduction											
		B 3	B 6	B 7	B 8	B 5	B 5I	B 5II	B 5III	V 1	V 3	V 5	V 6
SK 11E	quarts	0.26	0.37	0.37	0.58	0.32	0.53	0.42	0.42	0.32	0.37	0.42	0.53
	liters	0.25	0.35	0.35	0.55	0.30	0.50	0.40	0.40	0.30	0.35	0.40	0.50
SK 21E	quarts	0.63	1.06	1.06	1.27	0.53	1.16	0.95	0.95	0.74	1.48	1.06	1.27
	liters	0.60	1.00	1.00	1.20	0.50	1.10	0.90	0.90	0.70	1.40	1.00	1.20
SK 31E	quarts	1.16	1.80	1.80	2.32	0.85	1.74	2.11	2.11	1.16	1.37	2.43	2.85
	liters	1.10	1.70	1.70	2.20	0.80	1.65	2.00	2.00	1.10	1.30	2.30	2.70
SK 41E	quarts	1.80	2.75	2.75	3.49	1.06	2.96	3.49	3.49	1.69	2.75	2.64	2.75
	liters	1.70	2.60	2.60	3.30	1.00	2.80	3.30	3.30	1.60	2.60	2.50	2.60
SK 51E	quarts	2.32	3.59	3.59	4.97	1.90	4.33	4.02	4.02	3.17	3.70	4.23	4.65
	liters	2.20	3.40	3.40	4.70	1.80	4.10	3.80	3.80	3.00	3.50	4.00	4.40
Mounting position		double reduction											
		B 3	B 6	B 7	B 8	B 5	B 5I	B 5II	B 5III	V 1	V 3	V 5	V 6
SK 02	quarts	0.16	0.42	0.42	0.74	0.26	0.63	0.53	0.53	0.63	0.63	0.63	0.63
	liters	0.15	0.40	0.40	0.70	0.25	0.60	0.50	0.50	0.60	0.60	0.60	0.60
SK 12	quarts	0.26	0.53	0.53	0.90	0.37	0.95	0.63	0.63	0.95	0.90	0.79	0.79
	liters	0.25	0.50	0.50	0.85	0.35	0.90	0.60	0.60	0.90	0.85	0.75	0.75
SK 22	quarts	0.53	1.43	1.43	2.11	0.74	2.11	1.64	1.64	1.90	2.11	1.90	1.90
	liters	0.50	1.35	1.35	2.00	0.70	2.00	1.55	1.55	1.80	2.00	1.80	1.80
SK 32	quarts	0.95	2.11	2.11	3.17	1.37	3.49	2.54	2.54	3.28	3.06	3.06	2.64
	liters	0.90	2.00	2.00	3.00	1.30	3.30	2.40	2.40	3.10	2.90	2.90	2.50
SK 42	quarts	1.37	3.38	3.38	4.76	1.90	4.76	3.91	3.91	4.23	4.65	4.54	6.13
	liters	1.30	3.20	3.20	4.50	1.80	4.50	3.70	3.70	4.00	4.40	4.30	5.80
SK 52	quarts	2.64	5.39	5.39	7.19	3.17	6.55	5.92	5.92	7.82	7.19	7.19	7.40
	liters	2.50	5.10	5.10	6.80	3.00	6.20	5.60	5.60	7.40	6.80	6.80	7.00
SK 62	quarts	6.87	15.85	15.85	13.74	7.40	14.79	16.91	16.91	19.55	15.85	16.91	15.85
	liters	6.50	15.00	15.00	13.00	7.00	14.00	16.00	16.00	18.50	15.00	16.00	15.00
SK 72	quarts	9.51	24.30	24.30	19.02	10.57	19.55	24.30	24.30	29.59	24.30	27.47	24.30
	liters	9.00	23.00	23.00	18.00	10.00	18.50	23.00	23.00	28.00	23.00	26.00	23.00
SK 82	quarts	14.79	33.81	33.81	28.53	15.85	30.64	36.46	36.46	47.55	39.10	46.49	36.98
	liters	14.00	32.00	32.00	27.00	15.00	29.00	34.50	34.50	45.00	37.00	44.00	35.00
SK 92	quarts	26.42	54.95	54.95	49.66	27.47	49.66	54.95	54.95	82.42	77.14	80.31	77.14
	liters	25.00	52.00	52.00	47.00	26.00	47.00	52.00	52.00	78.00	73.00	76.00	73.00
SK 102	quarts	38.04	75.02	75.02	69.74	42.27	69.74	76.08	76.08	109.90	85.59	107.78	83.48
	liters	36.00	71.00	71.00	66.00	40.00	66.00	72.00	72.00	104.00	81.00	102.00	79.00
Mounting position		triple reduction											
		B 3	B 6	B 7	B 8	B 5	B 5I	B 5II	B 5III	V 1	V 3	V 5	V 6
SK 03	quarts	0.32	0.63	0.63	0.85	0.53	0.95	0.85	0.85	1.16	0.86	0.95	1.32
	liters	0.30	0.60	0.60	0.80	0.50	0.90	0.80	0.80	1.10	0.81	0.90	1.25
SK 13	quarts	0.63	0.74	0.74	1.16	0.85	1.27	1.00	1.00	1.27	1.27	1.27	1.32
	liters	0.60	0.70	0.70	1.10	0.80	1.20	0.95	0.95	1.20	1.20	1.20	1.25
SK 23	quarts	1.37	1.69	1.69	2.43	2.64	1.59	2.96	2.96	2.96	2.75	2.48	2.54
	liters	1.30	1.60	1.60	2.30	2.50	1.50	2.80	2.80	2.80	2.60	2.35	2.40
SK 33	quarts	1.69	2.43	2.43	3.38	2.01	3.70	2.75	2.75	4.65	3.59	4.44	3.06
	liters	1.60	2.30	2.30	3.20	1.90	3.50	2.60	2.60	4.40	3.40	4.20	2.90
SK 43	quarts	3.17	3.80	3.80	5.49	3.70	5.28	4.33	4.33	6.45	6.02	6.97	5.92
	liters	3.00	3.60	3.60	5.20	3.50	5.00	4.10	4.10	6.10	5.70	6.60	5.60
SK 53	quarts	4.76	6.34	6.34	8.14	5.49	7.40	7.08	7.08	9.40	8.88	9.19	9.19
	liters	4.50	6.00	6.00	7.70	5.20	7.00	6.70	6.70	8.90	8.40	8.70	8.70
SK 63	quarts	10.57	13.74	13.74	11.62	11.62	12.68	14.79	14.79	19.02	14.79	16.91	15.32
	liters	10.00	13.00	13.00	11.00	11.00	12.00	14.00	14.00	18.00	14.00	16.00	14.50
SK 73	quarts	14.79	21.13	21.13	18.49	14.79	19.02	21.13	21.13	29.06	23.78	28.53	21.13
	liters	14.00	20.00	20.00	17.50	14.00	18.00	20.00	20.00	27.50	22.50	27.00	20.00
SK 83	quarts	23.25	34.87	34.87	27.47	24.30	28.53	35.93	35.93	42.27	35.93	39.10	32.76
	liters	22.00	33.00	33.00	26.00	23.00	27.00	34.00	34.00	40.00	34.00	37.00	31.00
SK 93	quarts	42.27	51.78	51.78	46.49	42.27	46.49	51.78	51.78	78.19	73.97	76.08	73.97
	liters	40.00	49.00	49.00	44.00	40.00	44.00	49.00	49.00	74.00	70.00	72.00	70.00
SK 103	quarts	58.12	70.80	70.80	58.12	58.12	62.34	70.80	70.80	104.61	82.42	102.50	75.02
	liters	55.00	67.00	67.00	55.00	55.00	59.00	67.00	67.00	99.00	78.00	97.00	71.00

Note: Filling quantities are approximate figures. Oil level must be checked according to oil level plug after final installation. Acceptable oil fill level is within 1/2 inch of the bottom of the fill plug threads. For mounting angles not shown, consult factory.



## TROUBLE SHOOTING

PROBLEM WITH THE REDUCER		POSSIBLE CAUSES	SUGGESTED REMEDY
Runs Hot	Overloading	Load exceeds the capacity of the reducer	Check rated capacity of reducer, replace with unit of sufficient capacity or reduce load
	Improper lubrication	Insufficient lubrication	Check lubricant level and adjust up to recommended levels
		Excessive lubrication	Check lubricant level and adjust down to recommended levels
		Wrong lubrication	Flush out and refill with correct lubricant as recommended
Runs Noisy	Loose foundation bolts	Weak mounting structure	Inspect mounting of reducer. Tighten loose bolts and/ or reinforce mounting and structure
		Loose hold down bolts	Tighten bolts
	Worn RV Disc	Overloading unit may result in damage to disc	Disassemble and replace disc. Recheck rated capacity of reducer.
	Failure of Bearings	May be due to lack of lubricant	Replace bearing. Clean and flush reducer and fill with recommended lubricant.
		Overload	Check rated capacity of reducer.
Insufficient Lubricant	Level of lubricant in the reducer not properly maintained.	Check lubricant level and adjust to factory recommended level.	
Output Shaft Does Not Turn	Internal parts are broken	Overloading of reducer can cause damage.	Replace broken parts. Check rated capacity of reducer.
		Key missing or sheared off on input shaft.	Replace key.
		Coupling loose or disconnected.	Properly align reducer and coupling. Tighten coupling.
Oil Leakage	Worn Seals	Caused by dirt or grit entering seal.	Replace seals. Autovent may be clogged. Replace or clean.
		Overfilled reducer.	Check lubricant level and adjust to recommended level.
		Autovent clogged.	Clean or replace, being sure to prevent any dirt from falling into the reducer.
		Improper mounting position, such as wall or ceiling mount of horizontal reducer.	Check mounting position. Name tag & verify with mounting chart in manual.

### NORD Gear Corporation

National Customer Service Toll Free 888-314-6673

[www.nord.com](http://www.nord.com)

### NORD Gear Limited

Toll Free in Canada 800-668-4378

#### WEST

1121 Railroad Street  
Building 101  
Corona, CA 92882  
Phone 951-279-2600  
Fax 888-408-6673

#### MIDWEST

PO Box 367  
800 Nord Drive  
Waunakee, WI 53597  
Phone 608-849-7300  
Fax 800-373-6673

#### SOUTH

100 Forsyth Hall Dr.  
Building 100B  
Charlotte, NC 28273  
Phone 704-529-1255  
Fax 888-259-6673

#### CANADA

41 West Drive  
Brampton, Ontario L6T 4A1  
Phone 905-796-3606  
Fax 905-796-8130